

Service Manual

Washing Machine

Model:

DWD-FC1011/FC1012/FC1013/FC1211/FC1212/FC1213

DWD-FC1021/FC1022/FC1023/FC1221/FC1222/FC1223

DWD-FC1031/FC1032/FC1033/FC1231/FC1232/FC1233

DWD-FC1041/FC1042/FC1043/FC1241/FC1242/FC1243

DWD-FC1051/FC1052/FC1053/FC1251/FC1252/FC1253

DWD-FC1061/FC1062/FC1063/FC1261/FC1262/FC1263

DWD-FC1071/FC1072/FC1073/FC1271/FC1272/FC1273

DWD-FC1081/FC1082/FC1083/FC1281/FC1282/FC1283

DWD-FC1091/FC1092/FC1093/FC1094/FC1291/FC1292/

FC1293/FC1294

✓ Caution

: In this Manual, some parts can be changed for improving, their performance without notice in the parts list. So, if you need the latest parts information, please refer to PPL(Parts Price List) in Service Information Center (<http://svc.dwe.co.kr>).

DAEWOO ELECTRONICS CORP.

<http://svc.dwe.co.kr>

Aug. 2013

WASHING MACHINE

Contents

- 1. SPECIFICATIONS.....2**
- 2. INSTALLATION10**
 - Removing transit bolts10
 - Installation place requirement.....11
 - BS Plug Safety Details (For U.K. User).....11
 - Connecting inlet hose12
 - Installation of drain hose.....13
 - Level adjustment.....14
- 3. MAINTENANCE15**
 - Cleaning your washer15
 - Cold condition15
 - Cleaning the water inlet filter16
 - Cleaning the drain pump filter.....16
 - Cleaning the detergent case.....17
 - Cleaning the washing drum17
- 4. DIRECTION FOR DISASSEMBLY18**
- 5. EXPLODE VIEW AND PARTS LIST21**
- 6. FUNCTIONS OF THE CONTROL PANEL.....39**
- 7. FUNCTIONS OF THE CONTROLLER.....57**
- 8. FUNCTION OF THE CONVENIENT SERVICE.....60**
- 9. TROUBLESHOOTING GUIDE62**
- 10. WIRING DIAGRAM66**

1. SPECIFICATIONS

■ DWD-FC1X1X SERIES

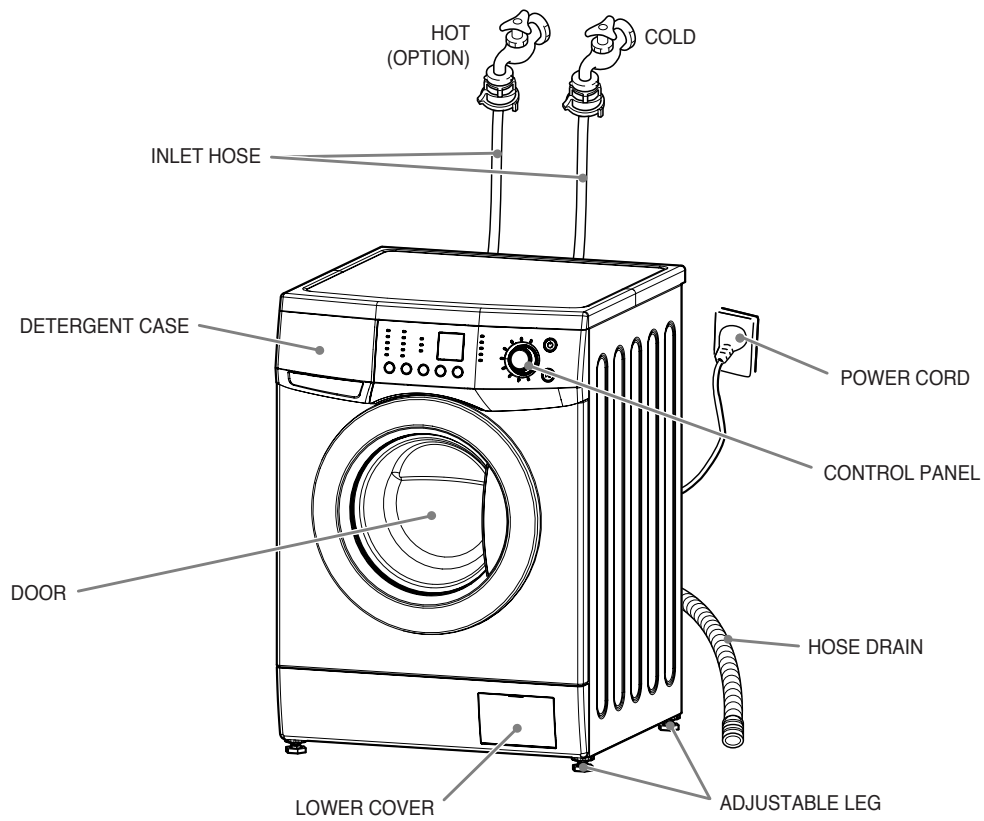

■ DWD-FC1X2X SERIES

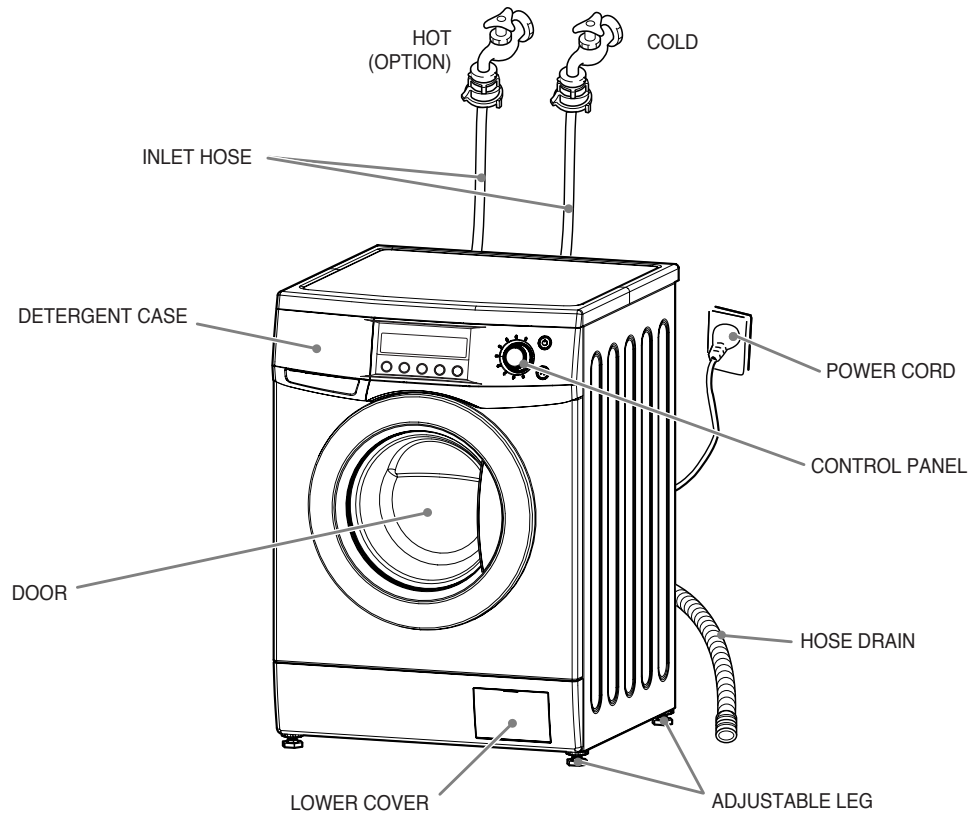

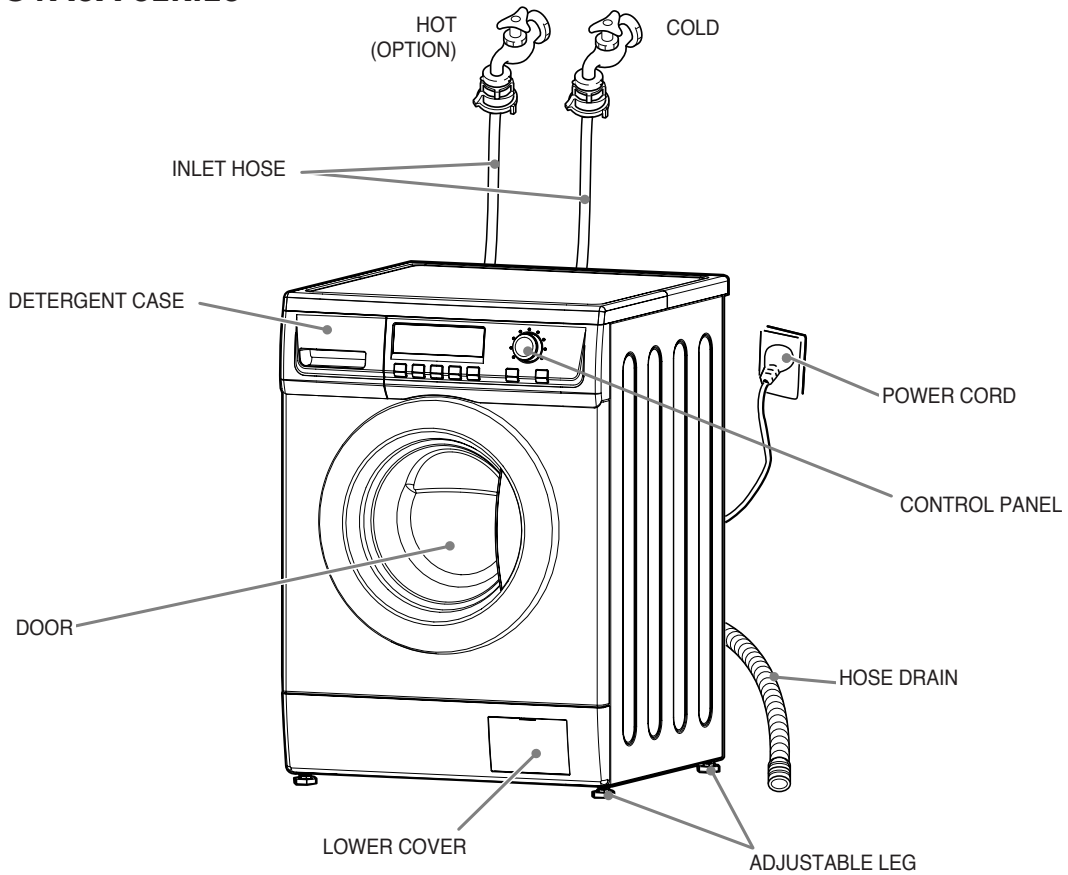

■ DWD-FC1X3X SERIES

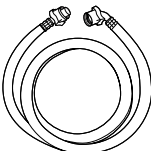

MODEL		DWD-FC1011/FC1012/FC1013/FC1211/FC1212/FC1213 DWD-FC1021/FC1022/FC1023/FC1221/FC1222/FC1223 DWD-FC1031/FC1032/FC1033/FC1231/FC1232/FC1233	
POWER SOURCE		220-240V, 50Hz	
DIMENSION (WXDXH)		595mm x 540mm x 850mm	
WEIGHT		59Kg(NET) / 63Kg(GROSS)	
WATER CONSUMPTION		47~59 ℓ	
POWER CONSUMPTION		2200W	
MAXIMUM MASS OF TEXTILE	WASH	6 / 6.5 / 7 kg	
	SPIN	6 / 6.5 / 7 kg	
WASHER TYPE		DRUM TYPE (FRONT LOADING WASHING MACHINE)	
OPERATING WATER PRESSURE		0.3 ~ 8kgf/cm ² (29.4 ~ 784kPa)	

■ Accessories

Inlet hose	Manual	Cap holder(3EA)
		

■ DWD-FC1X4X SERIES

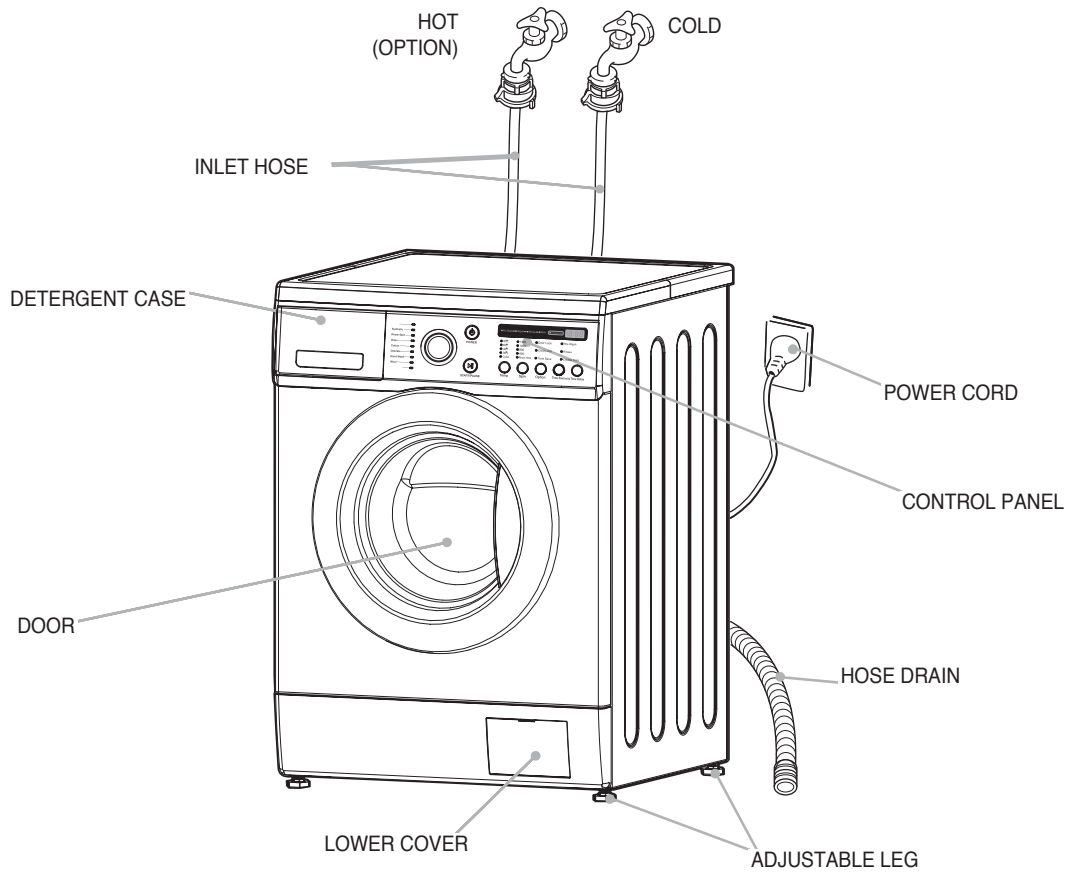

MODEL		DWD-FC1041/1042/1043/1241/1242/1243
POWER SOURCE		220-240V, 50/60Hz
DIMENSION (WDXH)		595mm x 540mm x 850mm
WEIGHT		59Kg(NET) / 63Kg(GROSS)
WATER CONSUMPTION		47~59 ℓ
POWER CONSUMPTION		2200W
MAXIMUM MASS OF TEXTILE	WASH	6 / 6.5 / 7 kg
	SPIN	6 / 6.5 / 7 kg
WASHER TYPE		DRUM TYPE (FRONT LOADING WASHING MACHINE)
OPERATING WATER PRESSURE		0.3 ~ 8kgf/cm ² (29.4 ~ 784kPa)

■ Accessories

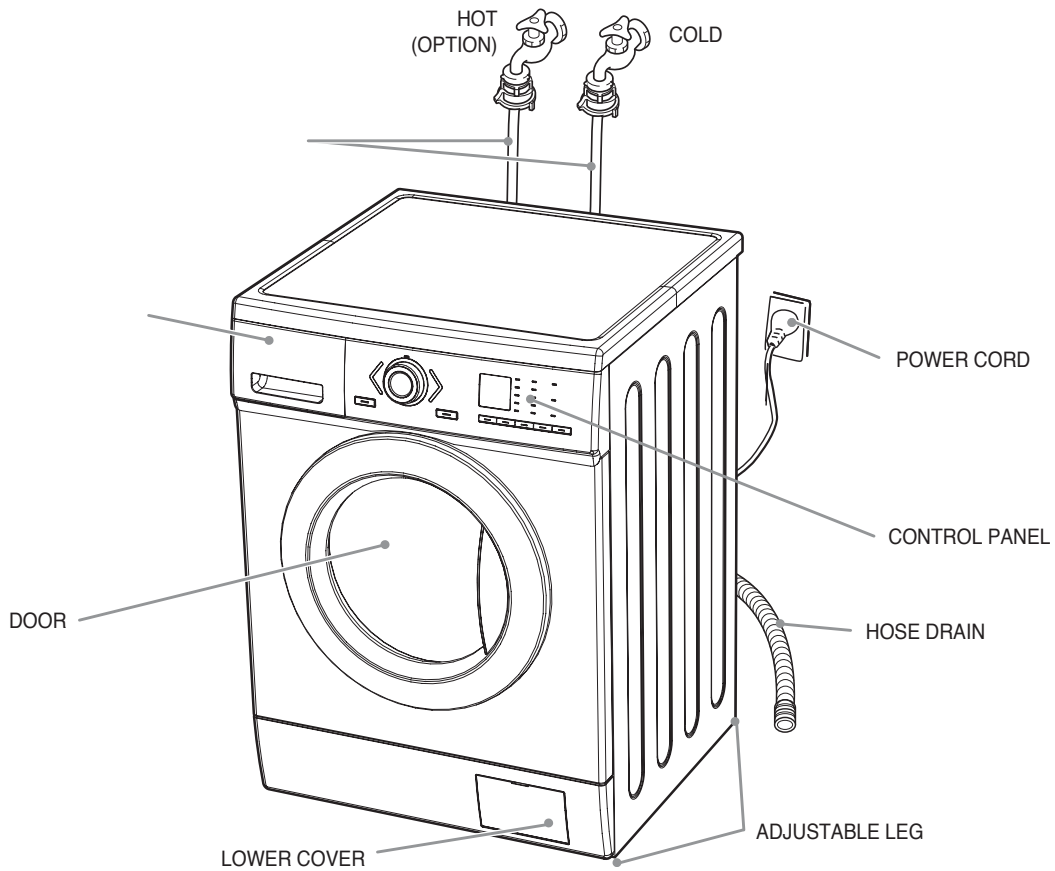

Inlet hose	Manual	Cap holder(3EA)

■ DWD-FC1X5X SERIES

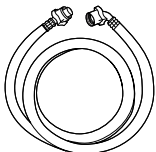
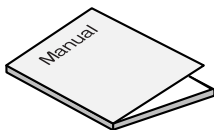

MODEL		DWD-FC1051/1052/1053/1251/1252/1253
POWER SOURCE		220-240V, 50/60Hz
DIMENSION (WXDXH)		595mm x 540mm x 850mm
WEIGHT		59Kg(NET) / 63Kg(GROSS)
WATER CONSUMPTION		47~59 ℓ
POWER CONSUMPTION		2200W
MAXIMUM MASS OF TEXTILE	WASH	6 / 6.5 / 7 kg
	SPIN	6 / 6.5 / 7 kg
WASHER TYPE		DRUM TYPE (FRONT LOADING WASHING MACHINE)
OPERATING WATER PRESSURE		0.3 ~ 8kgf/cm ² (29.4 ~ 784kPa)

■ Accessories

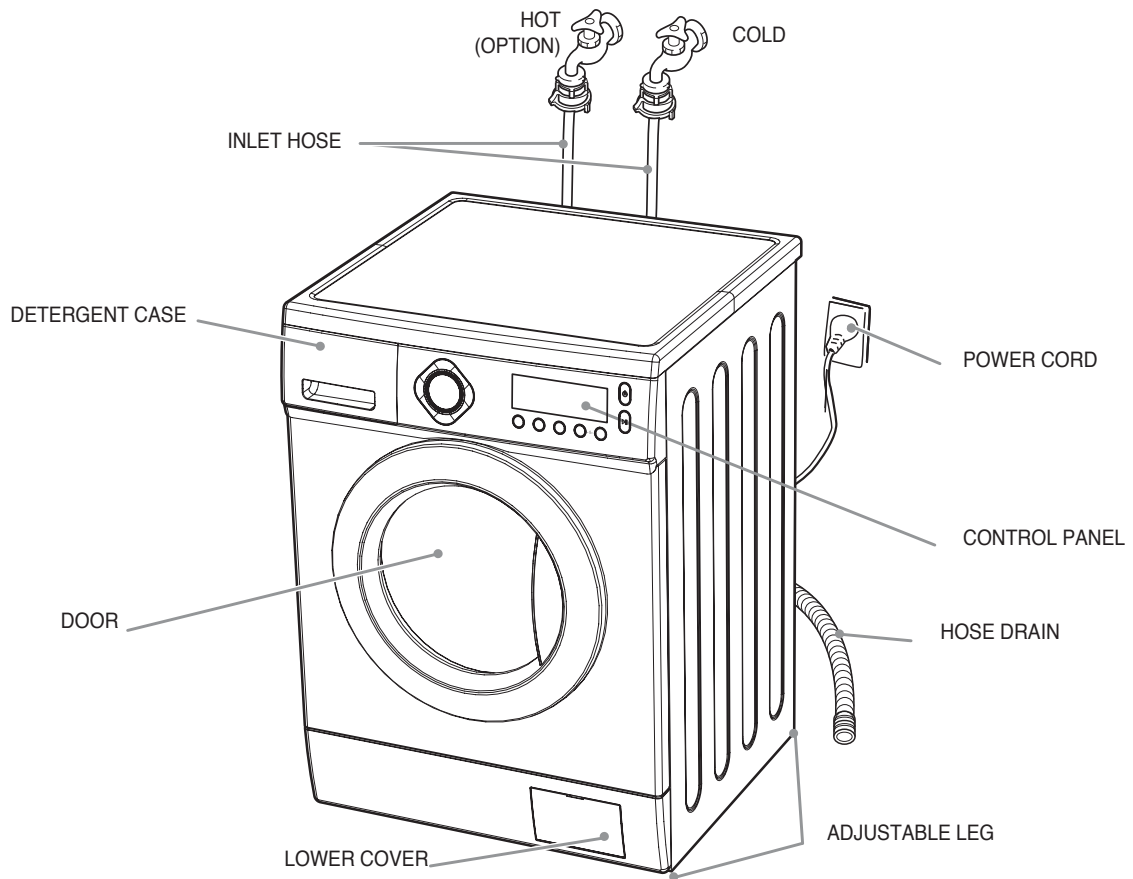

Inlet hose	Manual	Cap holder(3EA)
		

■ DWD-FC1X6X SERIES

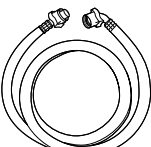
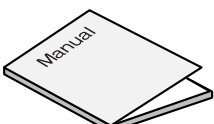

MODEL		DWD-FC1061/1062/1063/1261/1262/1263
POWER SOURCE		220-240V, 50/60Hz
DIMENSION (WxDxH)		595mm x 540mm x 850mm
WEIGHT		59Kg(NET) / 63Kg(GROSS)
WATER CONSUMPTION		47~59 ℓ
POWER CONSUMPTION		2200W
MAXIMUM MASS OF TEXTILE	WASH	6 / 6.5 / 7 kg
	SPIN	6 / 6.5 / 7 kg
WASHER TYPE		DRUM TYPE (FRONT LOADING WASHING MACHINE)
OPERATING WATER PRESSURE		0.3 ~ 8kgf/cm ² (29.4 ~ 784kPa)

■ Accessories

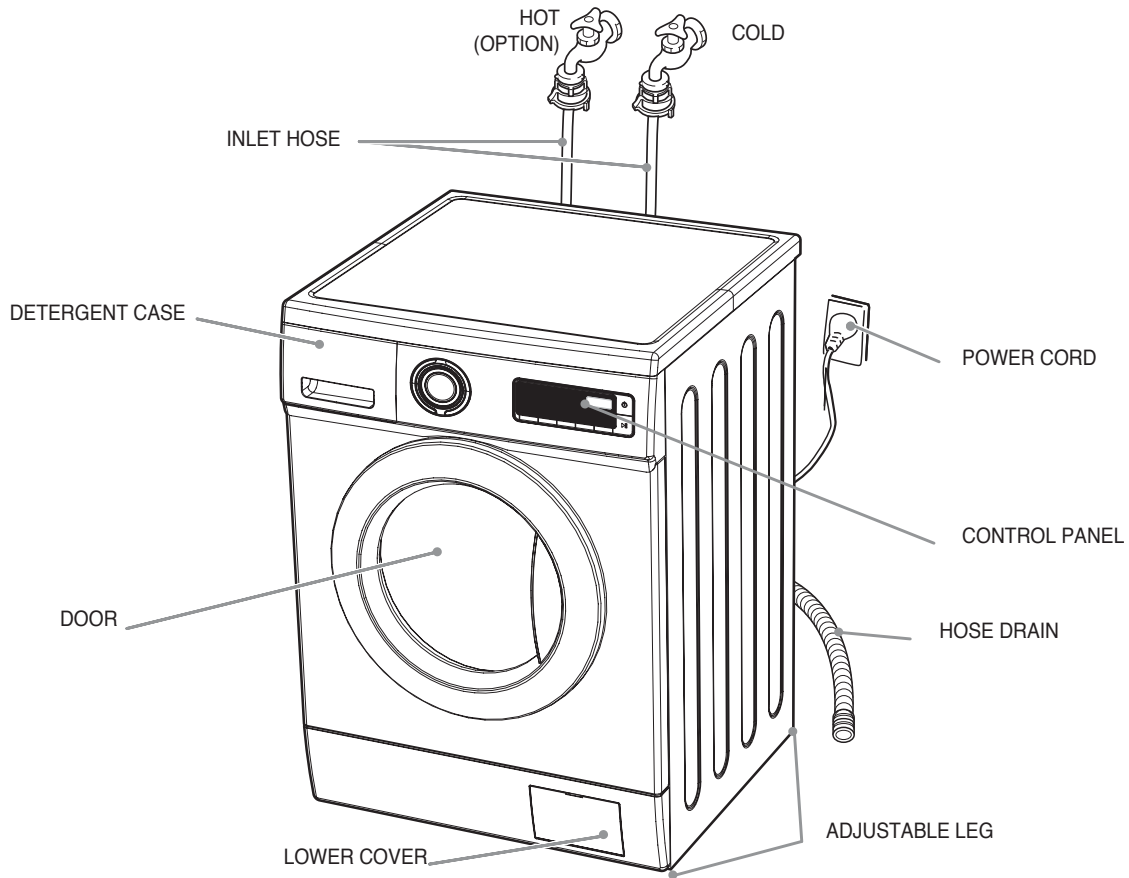

Inlet hose	Manual	Cap holder(3EA)
		

■ DWD-FC1X7X SERIES

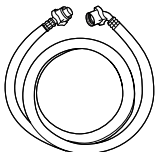
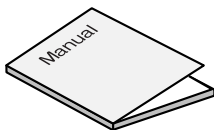

MODEL		DWD-FC1071/1072/1073/1271/1272/1273
POWER SOURCE		220-240V, 50/60Hz
DIMENSION (WXDXH)		595mm x 540mm x 850mm
WEIGHT		59Kg(NET) / 63Kg(GROSS)
WATER CONSUMPTION		47~59 ℓ
POWER CONSUMPTION		2200W
MAXIMUM MASS OF TEXTILE	WASH	6 / 6.5 / 7 / 8 kg
	SPIN	6 / 6.5 / 7 / 8 kg
WASHER TYPE		DRUM TYPE (FRONT LOADING WASHING MACHINE)
OPERATING WATER PRESSURE		0.3 ~ 8kgf/cm ² (29.4 ~ 784kPa)

■ Accessories

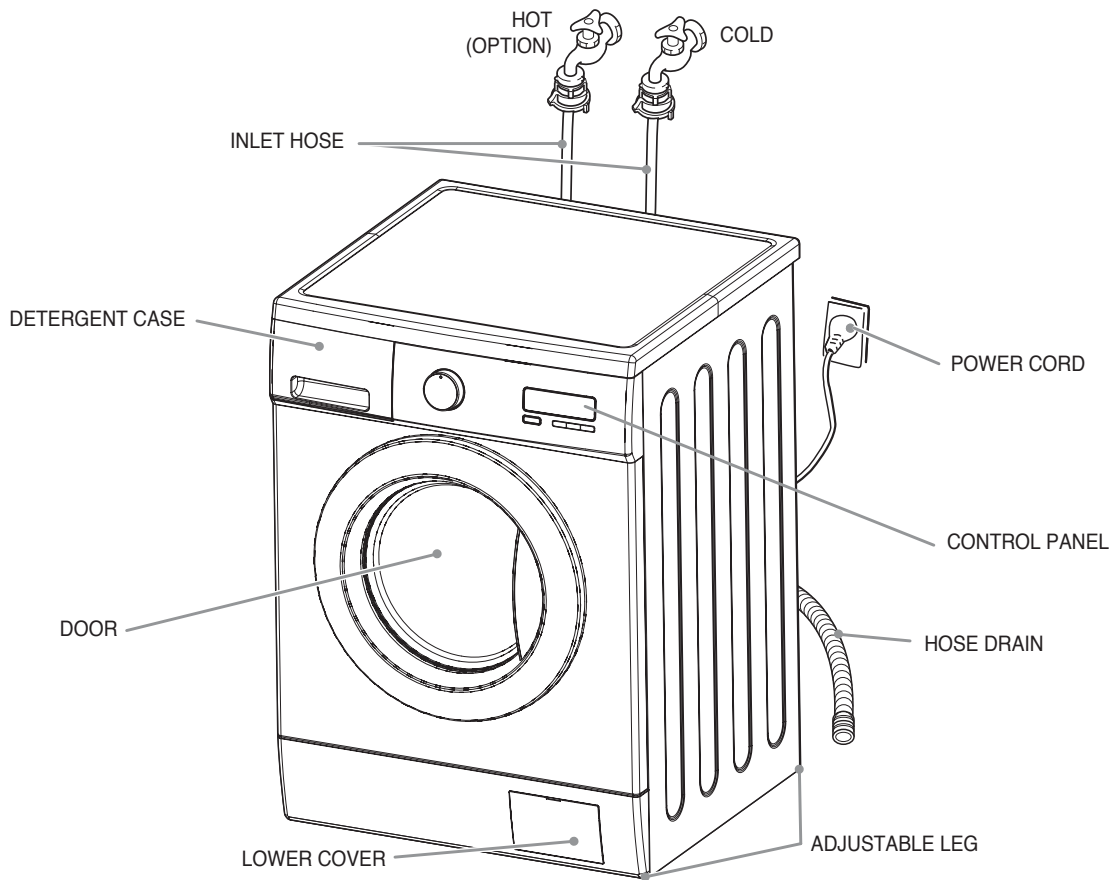

Inlet hose	Manual	Cap holder(3EA)
		

■ DWD-FC1X8X SERIES

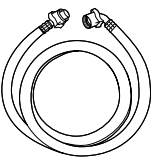
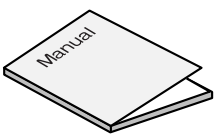

MODEL		DWD-FC1081/FC1082/FC1083/FC1084/FC1281/FC1282/FC1283
POWER SOURCE		220-240V, 50/60Hz
DIMENSION (WxDXH)		595MM x 590MM x 850MM
WEIGHT		59Kg(NET) / 63Kg(GROSS)
WATER CONSUMPTION		50 ℓ
POWER CONSUMPTION		2200W
MAXIMUM MASS OF TEXTILE	WASH	6 / 6.5 / 7 / 8 kg
	SPIN	6 / 6.5 / 7 / 8 kg
WASHER TYPE		DRUM TYPE (FRONT LOADING WASHING MACHINE)
OPERATING WATER PRESSURE		0.3 ~ 8kgf/cm ² (29.4 ~ 784kPa)

■ Accessories

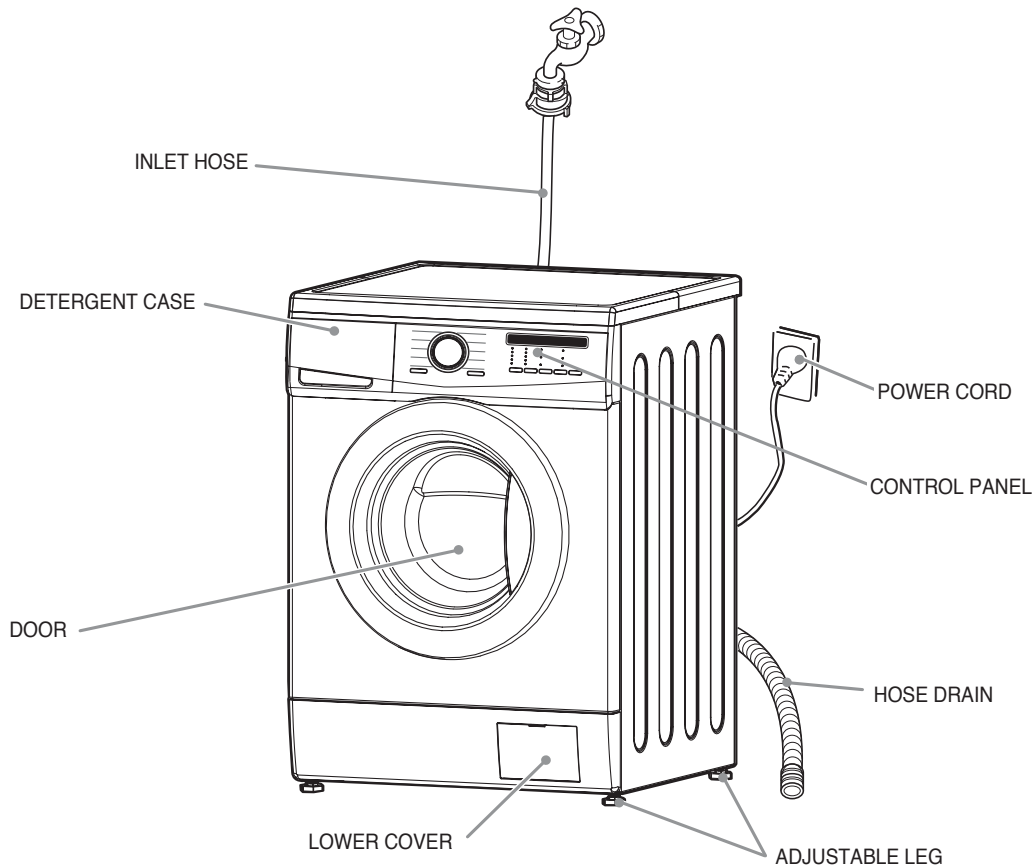

Inlet hose	Manual	Cap holder(3EA)
		

■ DWD-FC1X9X SERIES

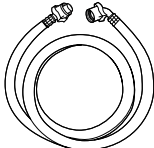

MODEL		DWD-FC1091/FC1092/FC1093/FC1094/FC1291/FC1292/FC1293/FC1294
POWER SOURCE		220-240V, 50/60Hz
DiMENSION (WXDXH)		595MM x 590MM x 850MM
WEIGHT		59Kg(NET) / 63Kg(GROSS)
WATER CONSUMPTION		50 ℓ
POWER CONSUMPTION		2200W
MAXIMUM MASS OF TEXTILE	WASH	6 / 6.5 / 7 / 8 kg
	SPIN	6 / 6.5 / 7 / 8 kg
WASHER TYPE		DRUM TYPE (FRONT LOADING WASHING MACHINE)
OPERATING WATER PRESSURE		0.3 ~ 8kgf/cm ² (29.4 ~ 784kPa)

■ Accessories

Inlet hose	Manual	Cap holder(3EA)
		

2. INSTALLATION

■ Transit bolts

The appliance is fitted with transit bolts to prevent internal damage during transport.

■ Removing transit bolts

1. To prevent internal damage during transport, the special 3 bolts are locked. Before operating the washer, remove the bolts along with the rubber bungs.

- If they are not removed, it may cause heavy vibration, noise and malfunction.

2. Unscrew the 3 bolts with the spanner supplied, and take out the 3 bolts with the rubber bungs. Keep the 3 bolts and the spanner for future use.

- Whenever the appliance is transported, the transit bolts must be refitted.

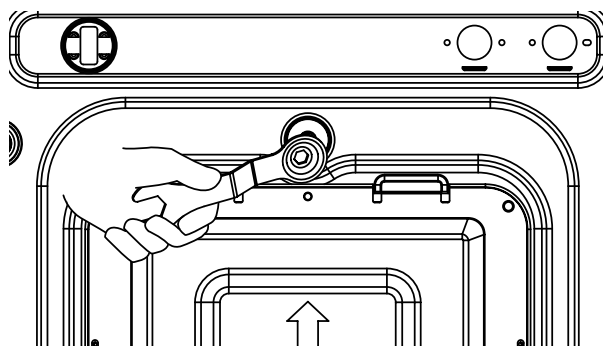
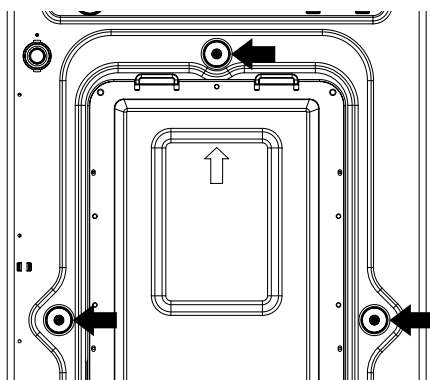

3. Close the holes with the caps supplied.

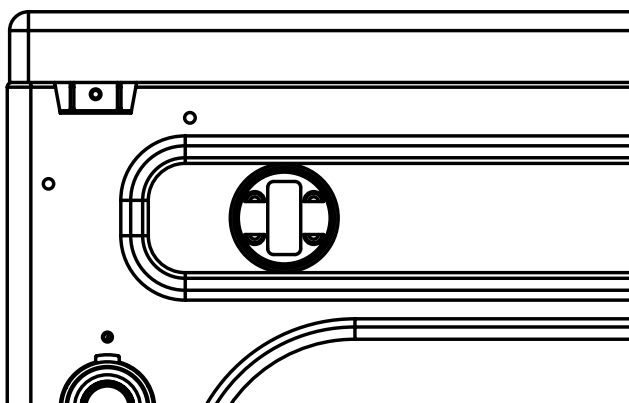

■ Installation place requirement

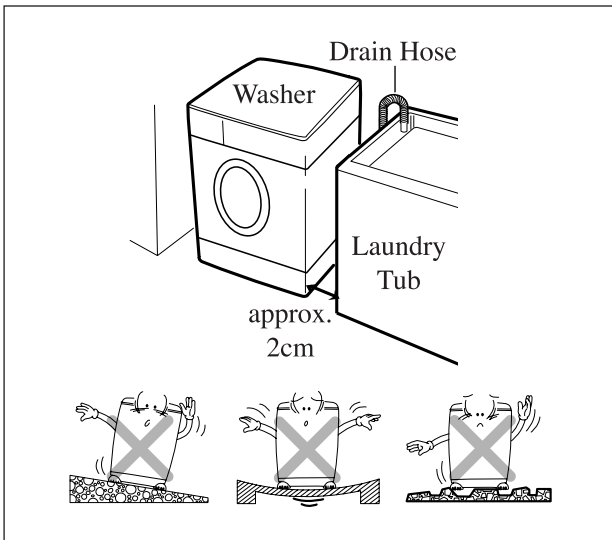

Level floor :

Allowable slope under entire washer is 1°.

Power outlet :

Must be with 1.5 meters of entire side of location of washer. Do not overload the outlet with more than one appliance.

Additional Clearance :

For wall, door and floor modeling is required.
(10cm : rear / 2cm : right & left side)

Do not place or store laundry products on top of washer at any times.

They can damage the finish or controls.

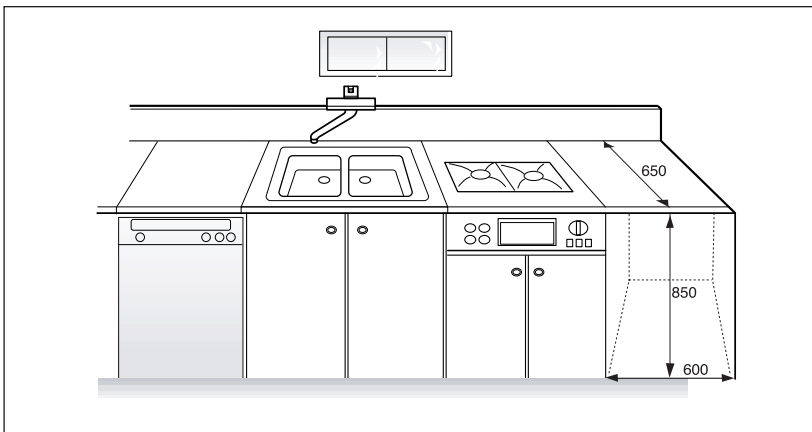

■ BS Plug Safety Details (For U.K. User)

IMPORTANT

THE WIRES IN THIS MAINS LEAD ARE COLOURED IN ACCORDANCE WITH THE FOLLOWING CODE:

GREEN AND YELLOW : EARTH

BLUE : NEUTRAL

BROWN : LIVE

This appliance must be earthed

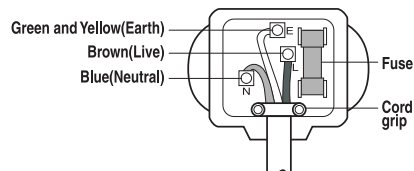

As the colours of the wires in the mains lead of this apparatus may not correspond with the coloured markings identifying the terminals in your plug, proceed as follows:

The wire which is coloured Green and Yellow must be connected to the terminal in the plug which is marked with the letter E or by the earth symbol \oplus or coloured Green or Green and Yellow.

The wire which is coloured Blue must be connected to the terminal which is marked with the letter N or coloured Black.

The wire which is coloured Brown must be connected to the terminal which is marked with the letter L or coloured Red.

If a 13 amp (BS 1363) plug is used, fit a 13amp BS 1362 fuse.

■ Connecting inlet hose

In using only one water tap or in case of only one water inlet valve, connect the inlet hose to the cold water inlet valve.
Option : Be careful not to confuse hot water inlet and cold water inlet.

•••• FOR ORDINARY TAP

- ① Pull down the collar of the inlet hose to separate it from the water tap adapter.

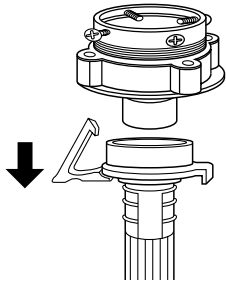

- ② Loosen the four screws properly in order to fit into water tap.

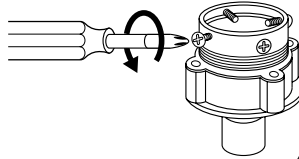

- ③ Fit the water tap adapter into the water tap and tighten the four screws evenly while pushing up the adapter so that the rubber packing can stick to the water tap tightly.

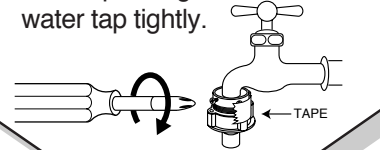

- ④ Remove the tape, and screw connector B into connector A tightly.

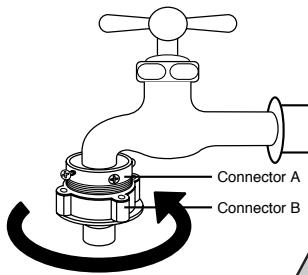

- ⑤ Connect the inlet hose to the water tap adapter by pulling down the collar of the hose end.

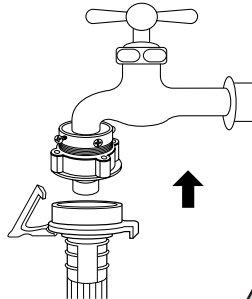

- ⑥ Connect the inlet hose adapter of the hose to the water inlet of the washer by turning it clockwise to be fixed tightly.

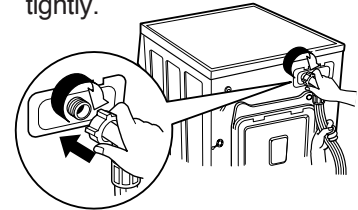

- Please check the rubber packing present inside the inlet hose adapter of the hose.

•••• FOR SCREW-SHAPED TAP

- ① Connect the inlet hose to the water tap adapter by pulling down the collar of the hose end.

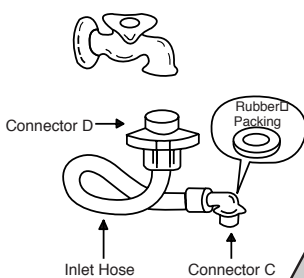

- ② Connect the connector-inlet supplied if necessary.

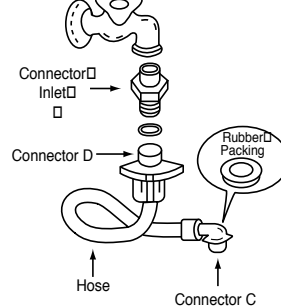

- ③ Connect the inlet hose adapter to the water inlet of the washer and turn it to be fixed.

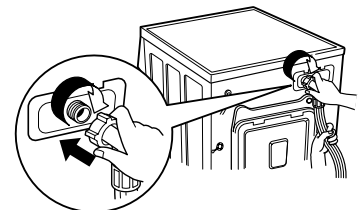

- Check the packing in the inlet.

■ Installation of drain hose

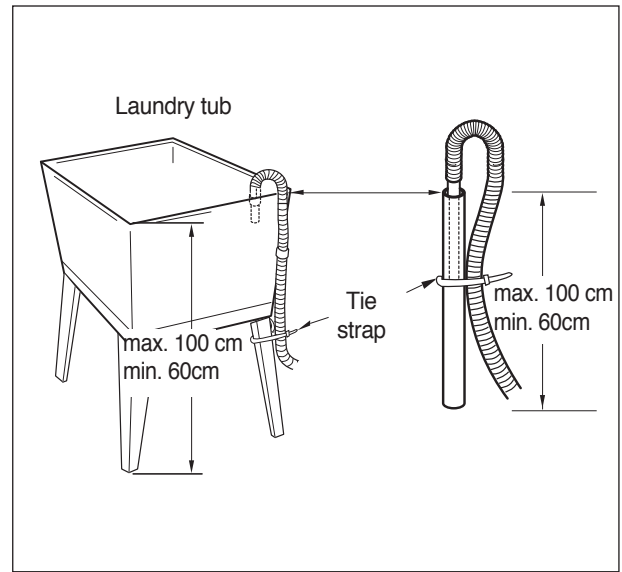
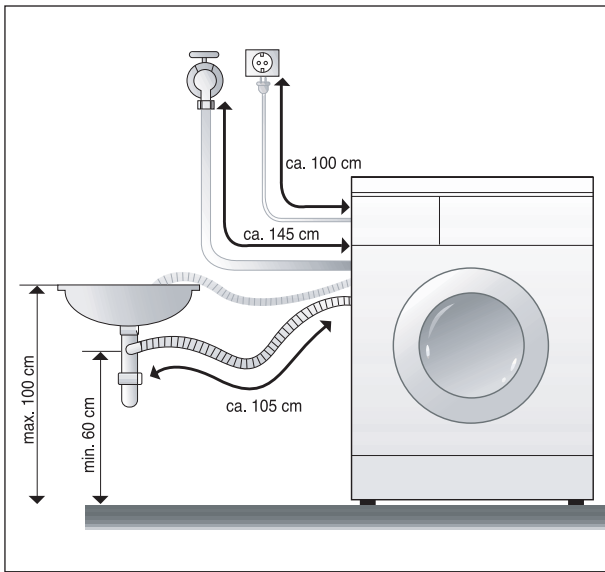

- The drain hose should not be placed higher than 100cm above the floor.
- Proper securing of the drain hose will protect the floor from damage due to water leakage.
- When the drain hose is too long, do not force back in to the washer. This cause abnormal noise.

■ Level adjustment



1. The level adjustment of the washing machine prevents excessive noise and vibration. Install the washing machine on a solid and even floor surface, if possible, in a corner of the room.

Note: The wooden floor may cause excessive vibration.

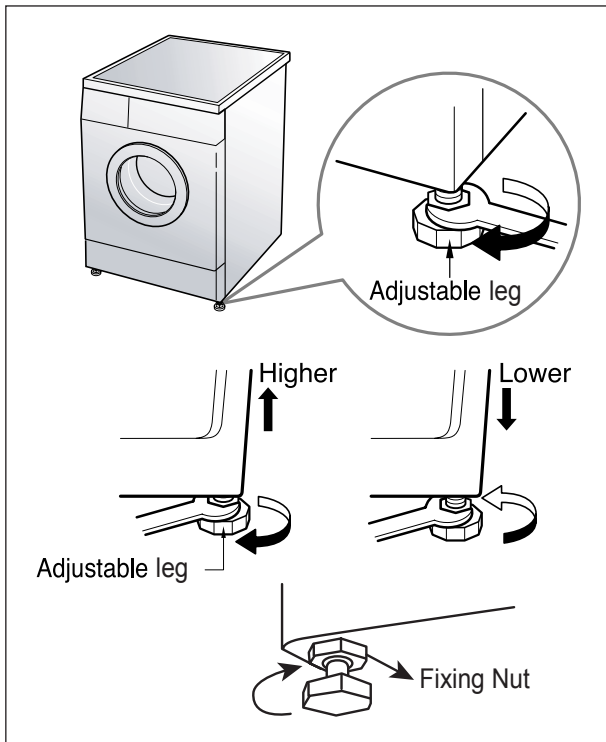

2. If the floor is uneven, adjust the adjustable leg as the following.
(Do not insert pieces of wood etc. under legs.)
 - Please check whether there is any gap between four adjustable legs and the floor.
 - Turn adjustable legs by the enclosed spanner in order to adjust the level of the washing machine.
 - Make it sure that there is no swaying of the washing machine and check that the washing machine is even completely. (use a spirit level)
 - After the level adjustment is finished, turn fixing nuts up tightly so that the washing machine maintains the adjustment.

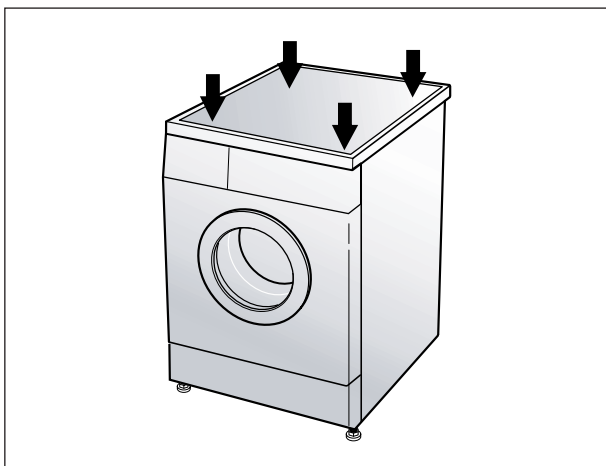

- * Diagonal Check
When pushing down the edges of the washing machine top plate diagonally, the machine should not move up and down at all.
(Please, check both of two directions)
If machine rocks when pushing the machine top plate diagonally, adjust legs again.

✱ Before cleaning the washer interior, unplug the electrical power cord avoid electrical shock hazards.

■ Cleaning your washer

1. Exterior

Proper care of your washer can extend its life.

The outside of the machine can be cleaned with warm water and a neutral non abrasive household detergent.

Immediately wipe off any spills. Wipe with damp cloth.

Try not to hit surface with sharp objects.

- Do not use methylated spirits, diluents or similar products.

2. Interior

Dry around the washer door opening, flexible gasket and door glass.

Run washer through a complete cycle using hot water.

Repeat process if necessary.

- Remove hard water deposits using only cleaners labeled as washer safe.

■ Cold condition

If the washer is stored in an area where freezing may occur or moved in freezing temperature, follow these instructions to prevent damage to the washer.

1. Turn off water supply tap.
2. Disconnect hoses from water supply and drain water from hoses.
3. Plug electrical cord into a properly grounded electrical outlet.
4. Add 1 gallon(3.8L) of nontoxic recreational vehicle(RV) antifreeze into empty wash drum.
Close the door.
5. Set spin cycle and let washer spin for 1 minute to drain out all water.
6. Unplug electrical power cord, dry the drum interior, and close the door.
7. Remove detergent case and dry excessive water from the compartments.
8. Store washer in an upright position.
9. To remove antifreeze from washer after storage, run empty washer through a complete cycle using detergent.
Do not add wash load.

■ Cleaning the water inlet filter

- "IE" error message will blink on the control panel when water does not enter the detergent drawer.
- If your water is very hard or contains traces of lime deposit, the water inlet filter may become clogged.
- It is therefore a good idea to clean it from time to time.

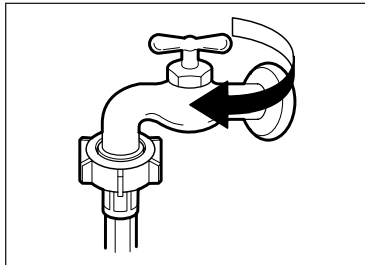

1. Turn off the water tap.

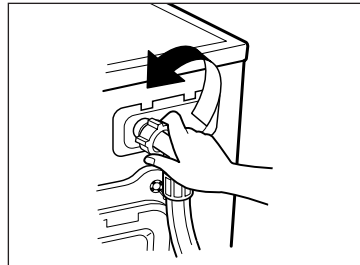

2. Unscrew the water inlet hose.

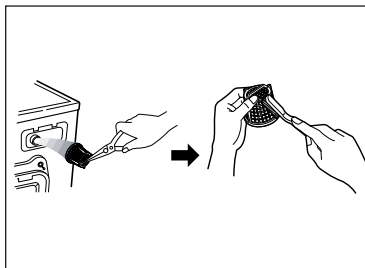

3. Clean the filter using a had bristle brush.

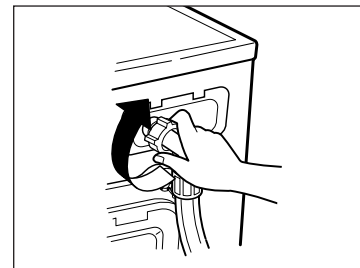

4. Tighten up the inlet hose.

■ Cleaning the drain pump filter

- The drain filter collects threads and small objects left in the laundry.
- Check regularly that the filter is clean to ensure smooth running of your machine.

CAUTION Be careful when draining if the water is hot.

1. Open the lower cover (①) by using a coin. Turn the cap hose (②) to pull out the hose. Pull out the hose maximally. (About 13~14cm.)

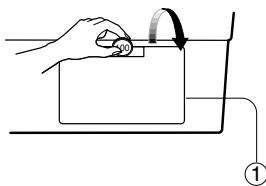

2. Unplug the cap hose (②), allowing the water to flow out. At this time use a vessel to prevent water flowing on to the floor. When water does not flow any more, turn the pump filter (③) open to the left.

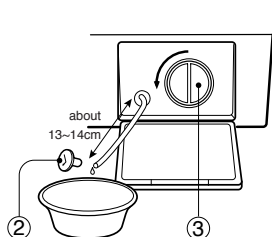

3. Remove any foreign material from the pump filter (③). After cleaning, turn the pump filter clockwise and insert the cap hose (②) to the original place. Close the lower cover.

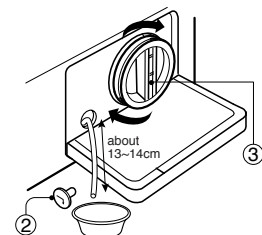

■ Cleaning the detergent case

✳ After a while detergents and fabric softeners leave a deposit in the detergent case.

- It should be cleaned from time to time with a jet of running water.
- If necessary it can be removed completely from the machine by pressing the catch downwards and by pulling it out.
- To facilitate cleaning, the upper part of the fabric softener compartment can be removed.

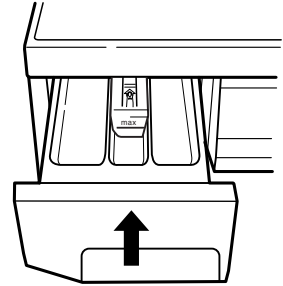
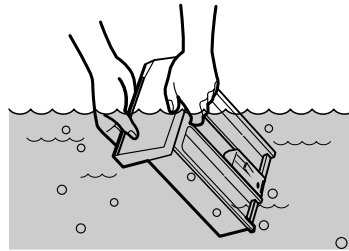
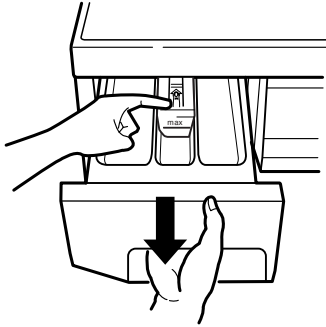

Inlet box recess

✳ Detergent can also accumulate inside the recess which should be cleaned occasionally with an old toothbrush.

- Once you have finished cleaning, replace the detergent case and run a rinse cycle without laundry.

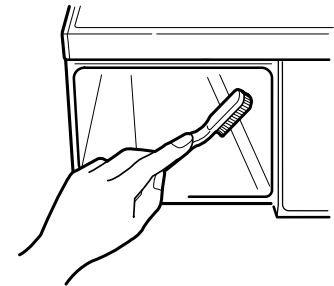

■ Cleaning the washing drum

- If you live in a hard water area, limescale may continuously build up in places where it cannot be seen and thus not easily removed.
- Over time the build up of scale clogs appliances, and if it is not kept in check these may have to be replaced.
- Although the washing drum is made of stainless steel, specks of rust can be caused by small metal articles (paper clips, safety pins) which have been left in the drum.
- The washing drum should be cleaned from time to time.
- If you use descaling agents, dyes or bleaches, make sure they are suitable for washing machine use.
- ✳ Descaler may contain chemicals that may damage part of your washing machine.
- ✳ Remove any spots with a stainless steel cleaning agent.
- ✳ Never use steel wool.

4. DIRECTION FOR DISASSEMBLY

DOOR LOCK SWITCH

1) Open the door and remove the gasket clamp.



2) Remove the gasket from the front cabinet.



3) Remove two screws, and remove the door lock switch.



HEATER AND THERMISTOR

1) Remove four screws on the back cover, and remove the back cover.



2) Remove connectors and the earth terminal.



3) Remove the nut by using a box wrench, and remove the earth terminal.

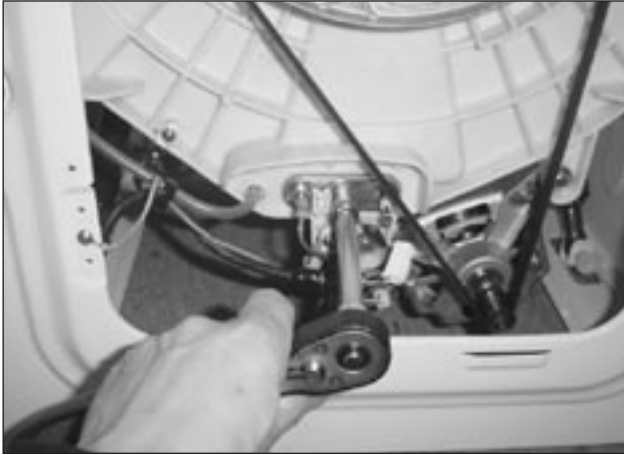

4) Loosen the nut by using a box wrench, and pull out the heater.



UNIVERSAL MOTOR

1) Remove the belt from the pulley.



2) Lay the right side of the washer on the floor, and remove the connector.



3) Remove two bolts and two nuts mounting the motor by using a box wrench.



4) Remove the motor from the tub.

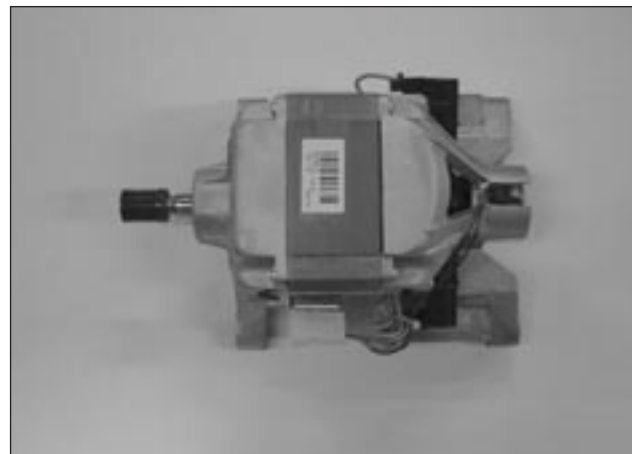

DRAIN PUMP

- 1) Lay the right side of the washer on the floor, and remove the lower panel by pressing six sanp fits.



- 2) Remove connectors.



- 3) Remove the screw, and remove the drain pump from the lower frame.



- 4) Remove the drain hose.



- 5) Remove the inner drain hose, and remove the drain pump.

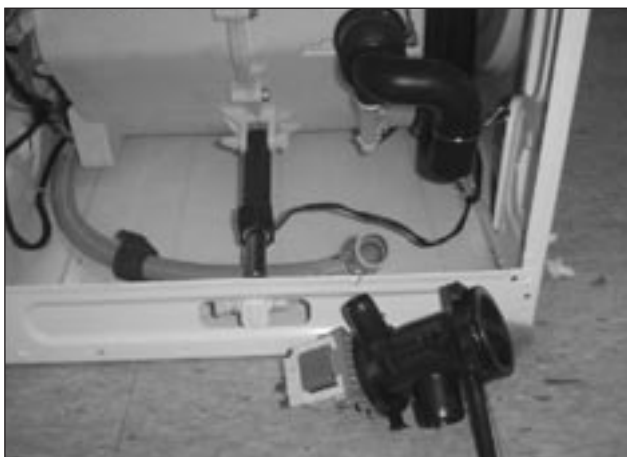

5. EXPLODE VIEW AND PARTS LIST

BOX INLET AS

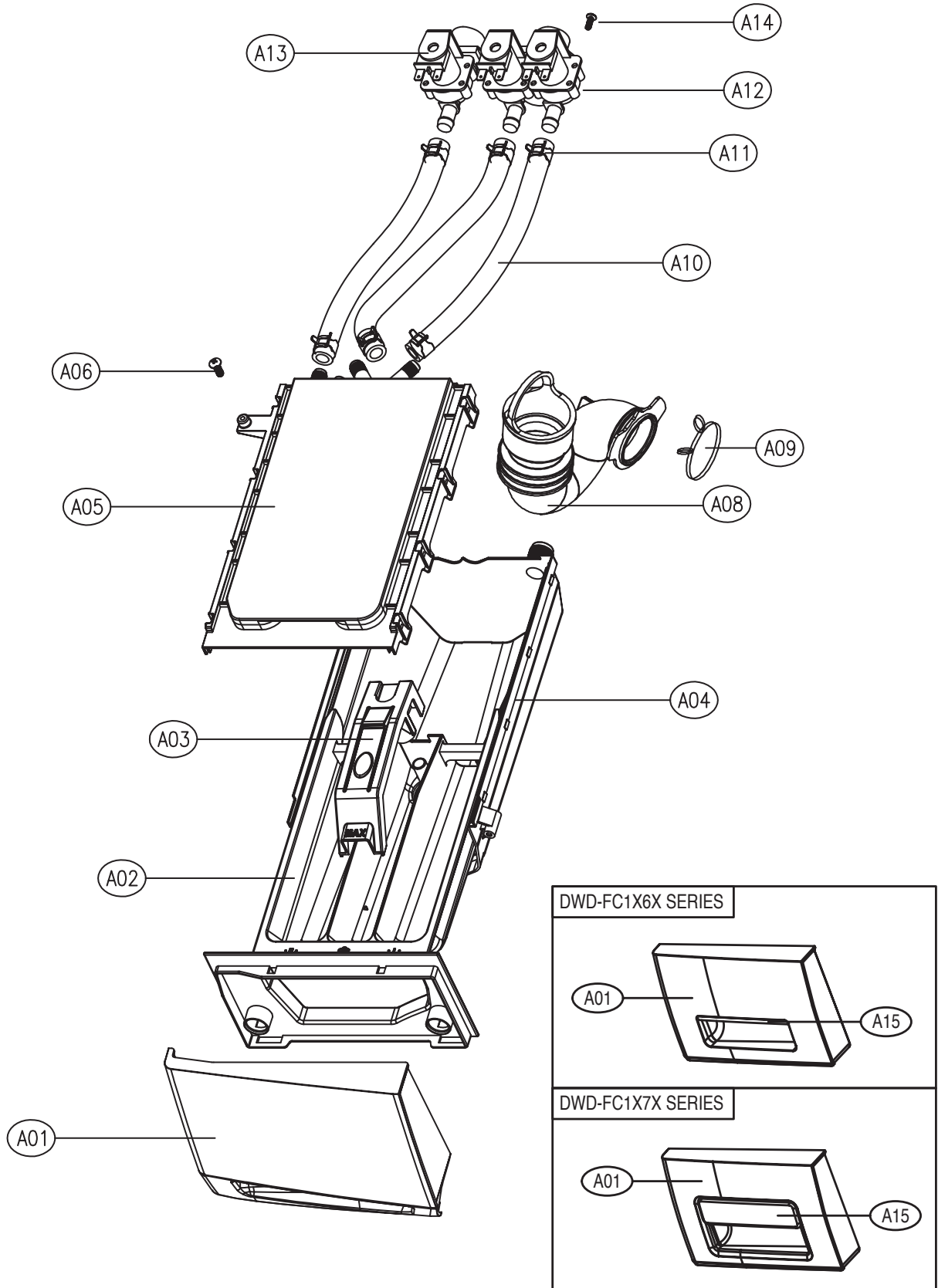

No.	PART NAME	PART CODE	SPECIFICATION	Q'TY	REMARK
A01	HANDLE CASE (CASE HANDLE)	3612608700	ABS	1	DWD-F1X11(2)
		3612608710	ABS + SPRAY		DWD-F1X13
		3612608900	ABS		DWD-F1X21(2)
		3612608910	ABS + SPRAY		DWD-F1X23
		3612609700	ABS		DWD-F1X31(2)
		3612609710	ABS + SPRAY		DWD-F1X33
		3611148000	HIPS, D-FU124'S		DWD-F1X41(2)
					DWD-F1X51(2)
		3611148001	ABS + SPRAY		DWD-F1X43
					DWD-F1X53
		3611149500	D-F'SERIES 6TH, ABS		DWD-F1X61(2)
		3611149510	ABS + SPRAY		DWD-F1X63
		3611149600	D-F'SERIES 7TH , ABS	DWD-F1X71(2)	
3611149610	ABS + SPRAY	DWD-F1X73			
	36111T3A00	ABS	1	DWD-F1X9'S	
A02	CASE DETERGENT	3611140300	PP	1	
A03	CAP SOFTENER	3610916600	PP	1	
A04	BOX INLET	3610526500	PP	1	
A05	NOZZLE AS	3618112200	NOZZLE TOP + NOZZLE UNDER	1	COLD
		3618105200			COLD+HOT
A06	SCREW TAPPING	7122402011	T2S TRS 4x20 MFZN	1	
A08	HOSE INLET	3613276600	EPDM U-TRAP	1	
A09	CLAMP HOSE I	3611201400	HSW3, D2.6, MFZN, ID=38	1	
A10	HOSE WATER SUPPLY	3613270900	EPDM, ID9.5, OD14.5, L=225	2(3)	COLD(+HOT)
A11	CLAMP HOSE	3611205800	100H, ID=13.8 W=10.0 0.9T	4(6)	COLD(+HOT)
A12	VALVE INET	3615414900	220-240V 2-WAY PP/BRACKET	1	COLD VALVE
		3615414910	220-240V 2WAY NYLON VDE		
		3615416821	220-240V.VDE.BITRON.2WAY + DR TECH		COLD VALVE(EU)
A13	VALVE INLET	3615414800	220-240V,50/60Hz,1WAY	1	HOT VALVE
		3615416720	220-240 50/60-1WAY,HOT,BITRON,VDE		HOT VALVE(EU)
A14	SCREW TAPTITE	7272400811	TT3 TRS 4X8 MFZN	2(4)	COLD(+HOT)
A15	DECO CASE HANDLE	3611698000	D-F'SERIES 6TH ,ABS	1	DWD-F1X6X
		3611698400	D-F'SERIES 7TH , ABS		DWD-F1X7X

BOX INLET AS (DWD-FC1X8X SERIES)

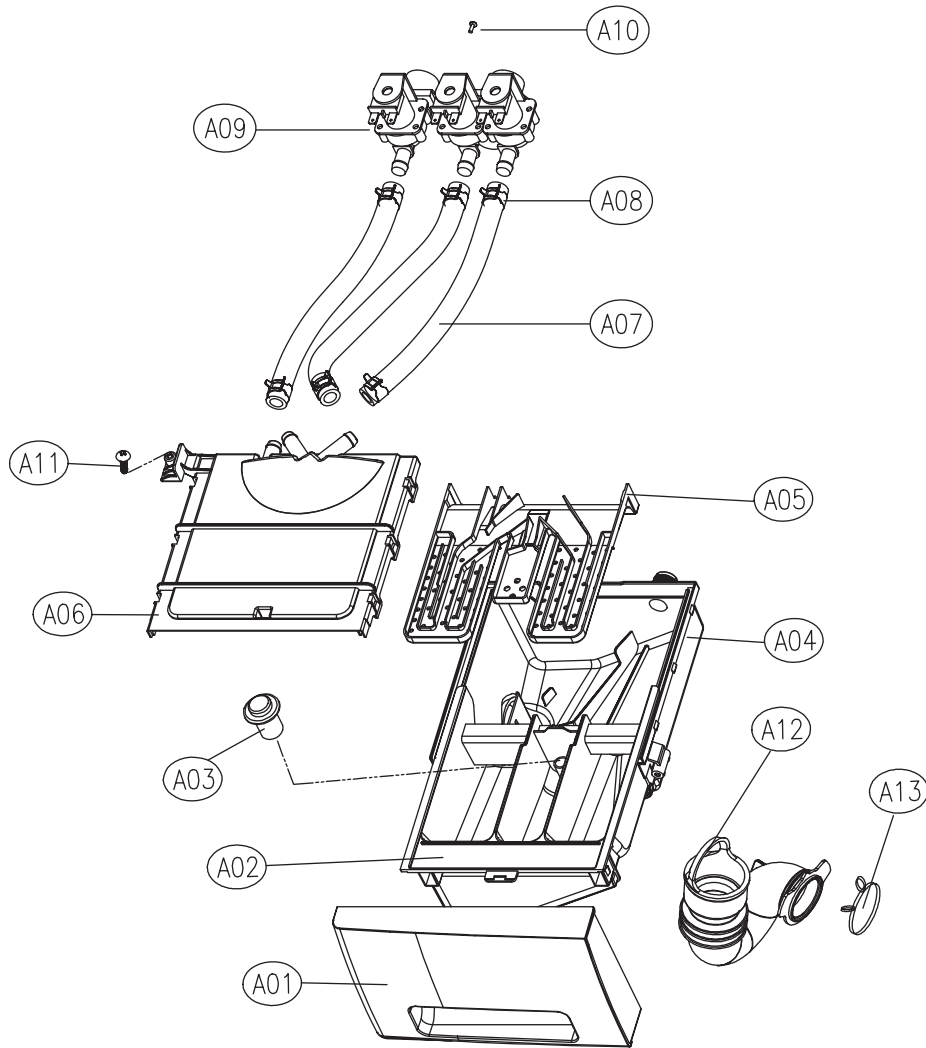

No.	PART NAME	PART CODE	SPECIFICATION	Q'TY	REMARK
A01	CASE HANDLE	36111T2W00	HIPS, FT1081	1	DWD-FT1*81
		-	ABS + SPRAY, FT1081	1	DWD-FT1*81
A02	CASE DETERGENT	3611145800	PP	1	DWD-FT1*81
A03	CAP SOFTENER	3610907800	PP	1	DWD-FT1*81
A04	INLET BOX	3617511800	PP, D-FU1081	1	DWD-FT1*81
A05	NOZZLE UNDER	3618103410	PP	1	M'S
A06	NOZZLE TOP	3618112200	PP, Cold only	1	DWD-FT1*81
		3618112210	PP, Cold + Hot	1	DWD-FT1*81
A07	HOSE WATER SUPPLY	3613270900	EPDM,ID9.5,OD14.5, L=310	2(3)	COLD(+HOT)
A08	CLAMP HOSE	3611205800	100H,ID=13.8,W=10,0.9T	4(6)	COLD(+HOT)
A09	VALVE INLET	3615414900	220~240V, 2-WAY, PP/BRACKET	1	COLD
		3615416821	220~240V, VDE,2-WAY+DR TECH INSPECTION COST		COLD(EU)
		3615414800	220~240V, 1-WAY, HOT PP/BRACKET	1	HOT(OPTION)
A10	SCREW TAPTITE	7272400811	TT3, TRS 4X8 MFZN	2(4)	COLD(+HOT)
A11	SCREW TAPPING	7122401411	T2S,TRS, 4X14 MFZN	1	
A12	HOSE INLET	3613276600	EPDM, FT1081	1	
A13	CLAMP HOSE	3611201401	HSW3,YW,D2.6,ID36,W44.5	1	

■ PANEL FRONT AS (DWD-FC1X1X SERIES)

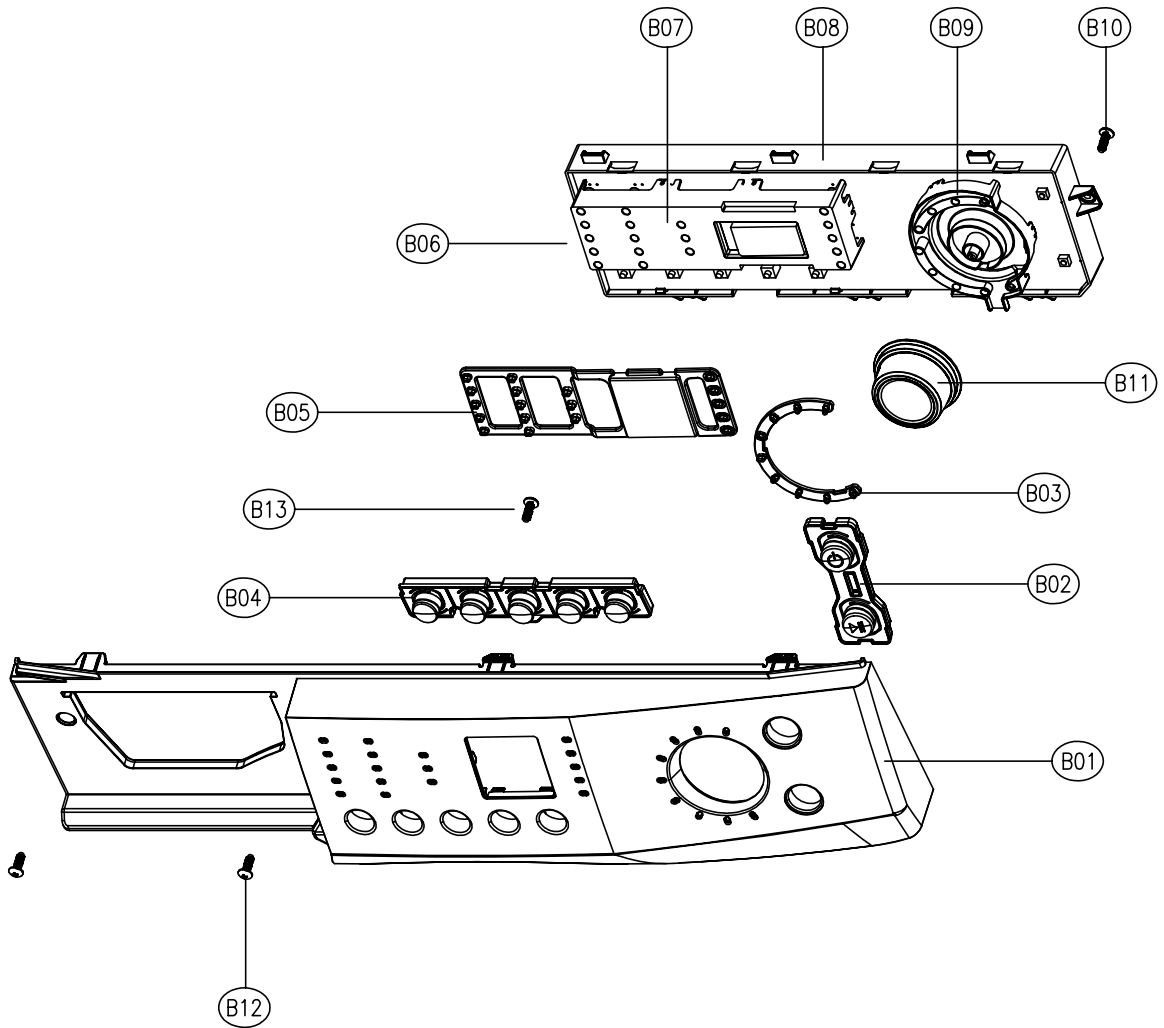

No.	PART NAME	PART CODE	SPECIFICATION	Q'TY	REMARK
B01	PANEL F	3614282702	HIPS	1	DWD-FT1X13
		3614282710	SILVER SPRAY		
B02	BUTTON POWER	3616603600	ABS	1	DWD-FT1X11/DWD-FT1X14
		3616603620	ABS+AL COATING		
B03	WINDOW DIAL	3615503100	ABS	1	
B04	BUTTON SELECT	3616603500	ABS	1	DWD-FT1X11/DWD-FT1X14
		3616603520	ABS+AL COATING		
B05	WINDOW LED	3615503000	ABS	1	
B06	PCB AS	PRPSSWB---	DWD-FT1XXX SERIES	1	Refer to Detailed Part Code of PCB AS
B07	HOLDER LED	3613049600	ABS	1	
B08	CASE PCB	3611140200	HIPS	1	
B09	HOLDER DIAL	3613049700	ABS	1	
B10	SCREW TAPPING	7122401611	T2S TRS 4x16 MFZN	4	
B11	KNOB DIAL AS	3613405000	ABS, AL COATING	1	DWD-FT1X13
		3613405010	ABS+SILVER SPRAY, UV COATING		
B12	SCREW TAPPING	7122401608	T2S TRS 4x16 SUS	2	
B13	SCREW TAPPING	7122401211	T2S TRS 4x12 MFZN	2	

■ PANEL FRONT AS (DWD-FC1X2X SERIES)

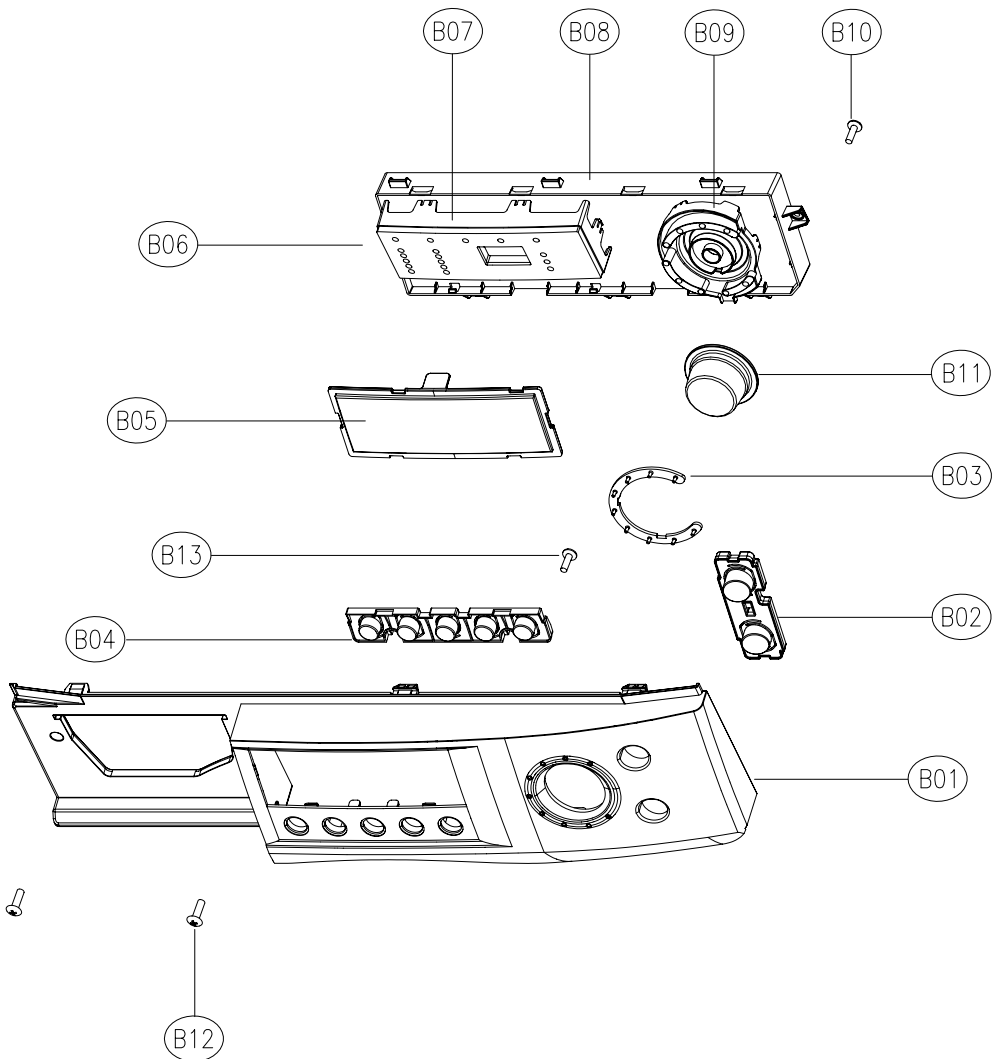

No.	PART NAME	PART CODE	SPECIFICATION	Q'TY	REMARK
B01	PANEL F	3614284502	HIPS	1	DWD-FT1X23
		3614284510	SILVER SPRAY		
B02	BUTTON POWER	3616604200	ABS	1	DWD-FT1X21
		3616604210	ABS+AL COATING		
B03	WINDOW DIAL	3615503400	ABS	1	
B04	BUTTON SELECT	3616604100	ABS	1	DWD-FT1X21
		3616604110	ABS+AL COATING	1	
B05	WINDOW LED	3615503300	ABS	1	
B06	PCB AS	PRPSSWB---	DWD-FT1XXX SERIES	1	Refer to Detailed Part Code of PCB AS
B07	HOLDER LED	3613050500	ABS	1	
B08	CASE PCB	3611140200	HIPS	1	
B09	HOLDER DIAL	3613050600	ABS	1	
B10	SCREW TAPPING	7122401611	T2S TRS 4x16 MFZN	4	
B11	KNOB DIAL	3613405110	ABS+SPRAY	1	
B12	SCREW TAPPING	7122401608	T2S TRS 4x16 SUS	2	
B13	SCREW TAPPING	7122401211	T2S TRS 4x12 MFZN	2	

■ PANEL FRONT AS (DWD-FC1X3X SERIES)

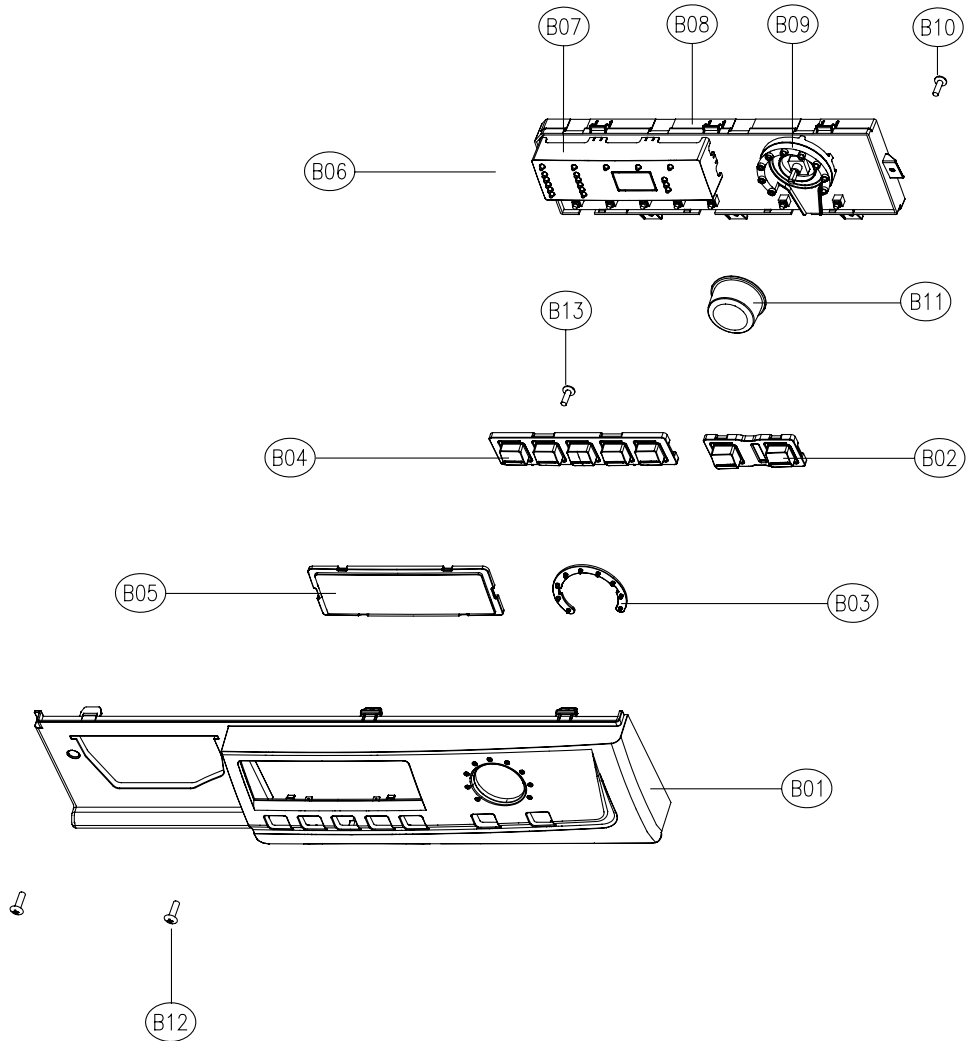

No.	PART NAME	PART CODE	SPECIFICATION	Q'TY	REMARK
B01	PANEL F	3614285802	HIPS	1	DWD-FT1X31(2)
		3614285810	ABS+SPRAY		DWD-FT1X33
B02	BUTTON POWER	3616635300	ABS	1	DWD-FT1X31
		3616635310	ABS+SPRAY		DWD-FT1X32(3)
B03	WINDOW DIAL	3615504200	ABS-TR	1	
B04	BUTTON SELECT	3616635400	ABS	1	DWD-FT1X31
		3616635410	ABS+SPRAY		DWD-FT1X32(3)
B05	WINDOW DISPLAY	3615504300	ABS-TR	1	
B06	PCB AS	PRPSSWB---	DWD-FT1XXX SERIES	1	Refer to Detailed Part Code of PCB AS
B07	HOLDER DISPLAY	3613051700	HIPS	1	
B08	CASE PCB	3611143200	HIPS	1	
B09	HOLDER DIAL	3613051500	HIPS	1	
B10	SCREW TAPPING	7122401611	T2S TRS 4x16 MFZN	4	
B11	KNOB DIAL	3613405210	ABS+SPRAY	1	
B12	SCREW TAPPING	7122401608	T2S TRS 4x16 SUS	2	
B13	SCREW TAPPING	7122401211	T2S TRS 4x12 MFZN	2	

■ PANEL FRONT AS (DWD-FC1X4X SERIES)

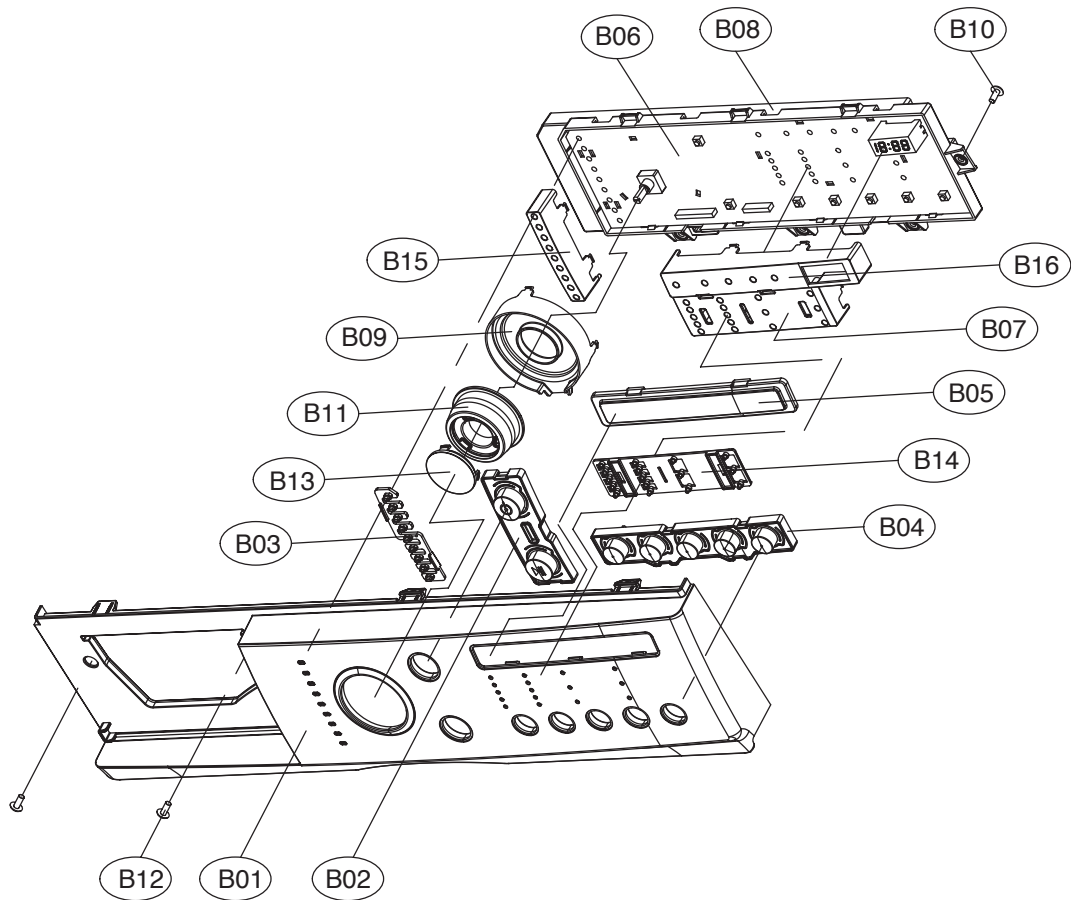

No.	PART NAME	PART CODE	SPECIFICATION	Q'TY	REMARK
B01	PANEL F	36142T1502	HIPS	1	DWD-FT1X41(2)
		36142T1510	ABS + SPRAY		DWD-FT1X43
B02	BUTTON POWER	3616639100	ABS	1	DWD-FT1X41
		3616639110	ABS + SPRAY		DWD-FT1X42(3)
B03	WINDOW COURSE	3615507000	ABS-TR	1	
B04	BUTTON SELECTION	3616639000	ABS	1	DWD-FT1X41
		3616639010	ABS + SPRAY		DWD-FT1X42(3)
B05	WINDOW DISPLAY	3615506800	ABS-TR	1	
B06	PCB AS	PRPSSWB---	DWD-FT1X4X SERIES	1	Refer to Detailed Part Code of PCB AS
B07	HOLDER LED SELECTION	3613055300	HIPS	1	
B08	CASE PCB	36111T1500	HIPS	1	
B09	HOLDER DIAL	3613055500	HIPS	1	
B10	SCREW TAPPING	7122401611	T2S TRS 4x16 MFZN	4	
B11	KNOB DIAL OUTER	3613406600	ABS	1	DWD-FT1X41
		3613406610	ABS + SPRAY		DWD-FT1X42(3)
B12	SCREW TAPPING	7122401608	T2S TRS 4x16 SUS	2	
B13	KNOB DIAL INNER	3613406700	ABS	1	DWD-FT1X41
		3613406710	ABS + SPRAY		DWD-FT1X42(3)
B14	WINDOW SELECTION	3615506900	ABS-TR	1	
B15	HOLDER LED COURSE	3613055400	HIPS	1	
B16	DECORATOR WINDOW	3611689900	PC FILM	1	

■ PANEL FRONT AS (DWD-FC1X5X SERIES)

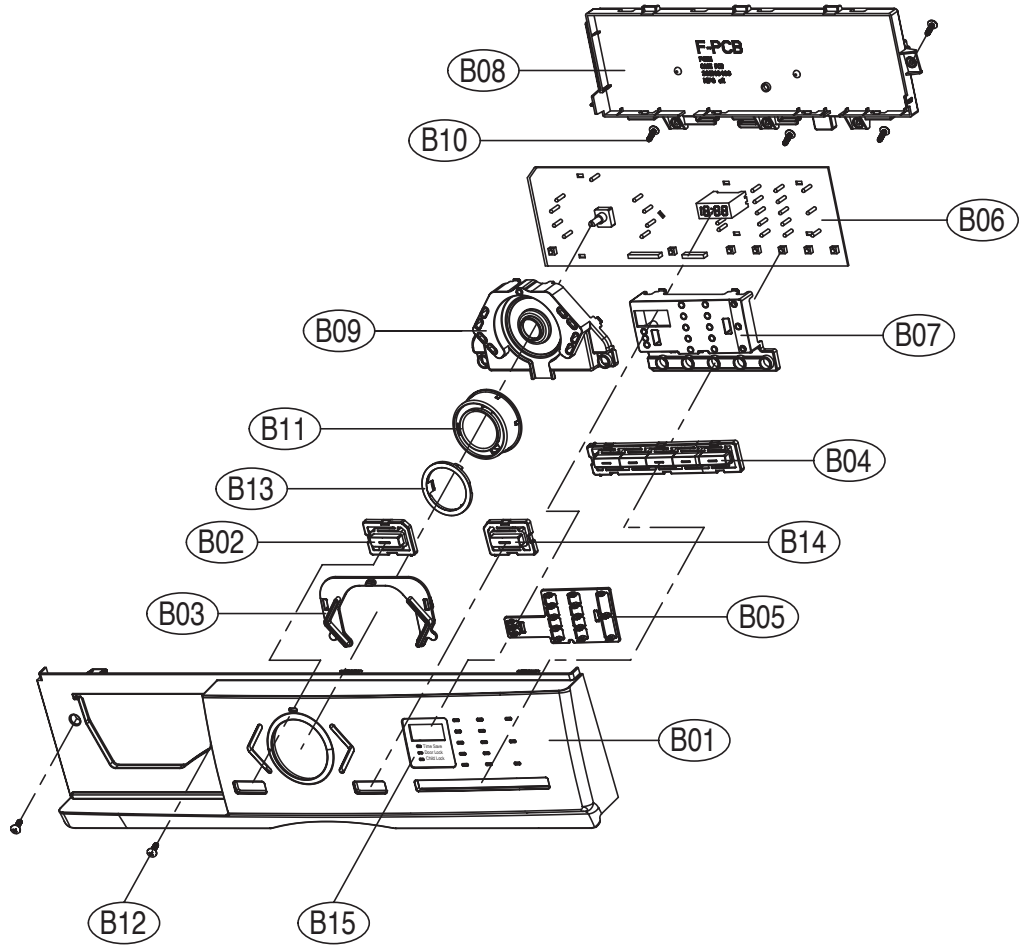

No.	PART NAME	PART CODE	SPECIFICATION	Q'TY	REMARK
B01	PANEL F	3614290100	HIPS, D-FU125'S	1	DWD-FT1X51(2)
		3614290110	ABS D-FU1253'S		DWD-FT1X53
B02	BUTTON POWER	3616644900	ABS	1	DWD-FT1X51(2)
		3616644910	ABS + SPRAY		DWD-FT1X53
B03	WINDOW COURSE	3615509500	ABS-TR	1	DWD-FT1X5X
B04	BUTTON FUNCTION	3616645100	ABS	1	DWD-FT1X51(2)
		3616645110	ABS + SPRAY		DWD-FT1X53
B05	WINDOW SELECTION	3615509600	ABS-TR	1	DWD-FT1X5X
B06	PCB AS	PRPSSWB---	DWD-FT1X5X SERIES	1	Refer to Detailed Part Code of PCB AS
B07	HOLDER LED FUNCTION	3613058800	HIPS	1	DWD-FT1X5X
B08	CASE PCB	3611149400	HIPS	1	DWD-FT1X5X
B09	HOLDER LED COURSE	3613058700	HIPS	1	DWD-FT1X5X
B10	SCREW TAPPING	7122401611	T2S TRS 4x16 MFZN	4	
B11	BUTTON DIAL	3616644800	ABS	1	DWD-FT1X51(2)
		3616644810	ABS + SPRAY		DWD-FT1X53
B12	SCREW TAPPING	7122401608	T2S TRS 4x16 SUS	2	
B13	DECORATOR BUTTON DIAL	3611696400	ABS, GILDING	1	DWD-FT1X5X
B14	BUTTON START	3616645000	ABS	1	DWD-FT1X51(2)
		3616645010	ABS + SPRAY		DWD-FT1X53
B15	DECORATOR FILM	3611689900	P.C FILM	1	DWD-FT1X5X

■ PANEL FRONT AS (DWD-FC1X6X SERIES)

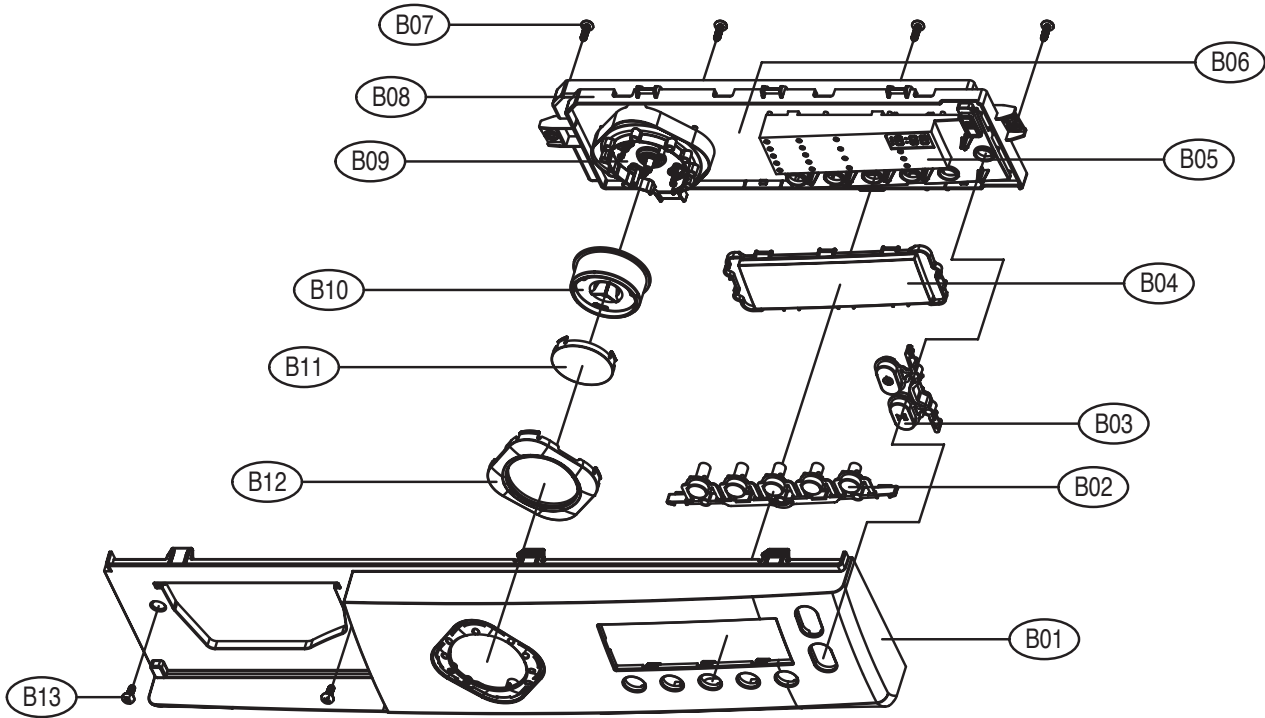

No.	PART NAME	PART CODE	SPECIFICATION	Q'TY	REMARK
B01	PANEL F	36142T3000	D-F'SERIES 6TH , ABS	1	DWD-FT1X61(2)
		36142T3010	D-F'SERIES 6TH , ABS+ SPRAY		DWD-FT1X63
B02	BUTTON SELECT	3616645800	D-F'SERIES 6TH , ABS	1	DWD-FT1X61(2)
		3616645810	D-F'SERIES 6TH , ABS+ SPRAY		DWD-FT1X63
B03	BUTTON POWER	3616645900	D-F'SERIES 6TH , ABS	1	DWD-FT1X61(2)
		3616645910	D-F'SERIES 6TH , ABS+ SPRAY		DWD-FT1X63
B04	WINDOW DISPLAY	3615510300	D-F'SERIES 6TH , TR ABS	1	DWD-FT1X6X
B05	HOLDER LED	3613061900	D-F'SERIES 6TH , HIPS	1	DWD-FT1X6X
B06	PCB AS	PRPSSWB----	D-FT1X6X SERIES	1	Refer to Detailed Part Code of PCB AS
B07	SCREW TAPPING	7122401611	T2S TRS 4x16 MFZN	4	
B08	CASE PCB	3611149700	D-F'SERIES 6TH / 7TH, HIPS	1	DWD-FT1X6(7)X
B09	HOLDER LED COURSE	3613061800	D-F'SERIES 6TH , HIPS	1	DWD-FT1X6X
B10	BUTTON DIAL	3616645700	D-F'SERIES 6TH , ABS	1	DWD-FT1X61(2)
		3616645710	D-F'SERIES 6TH , ABS+ SPRAY		DWD-FT1X63
B11	DECO BUTTON DIAL	3611698100	D-F'SERIES 6TH , ABS	1	DWD-FT1X6X
B12	WINDOW COURSE	3615510400	D-F'SERIES 6TH , TR ABS	1	DWD-FT1X6X
B13	SCREW TAPPING	7122401608	T2S TRS 4x16 SUS	2	

■ PANEL FRONT AS (DWD-FC1X7X SERIES)

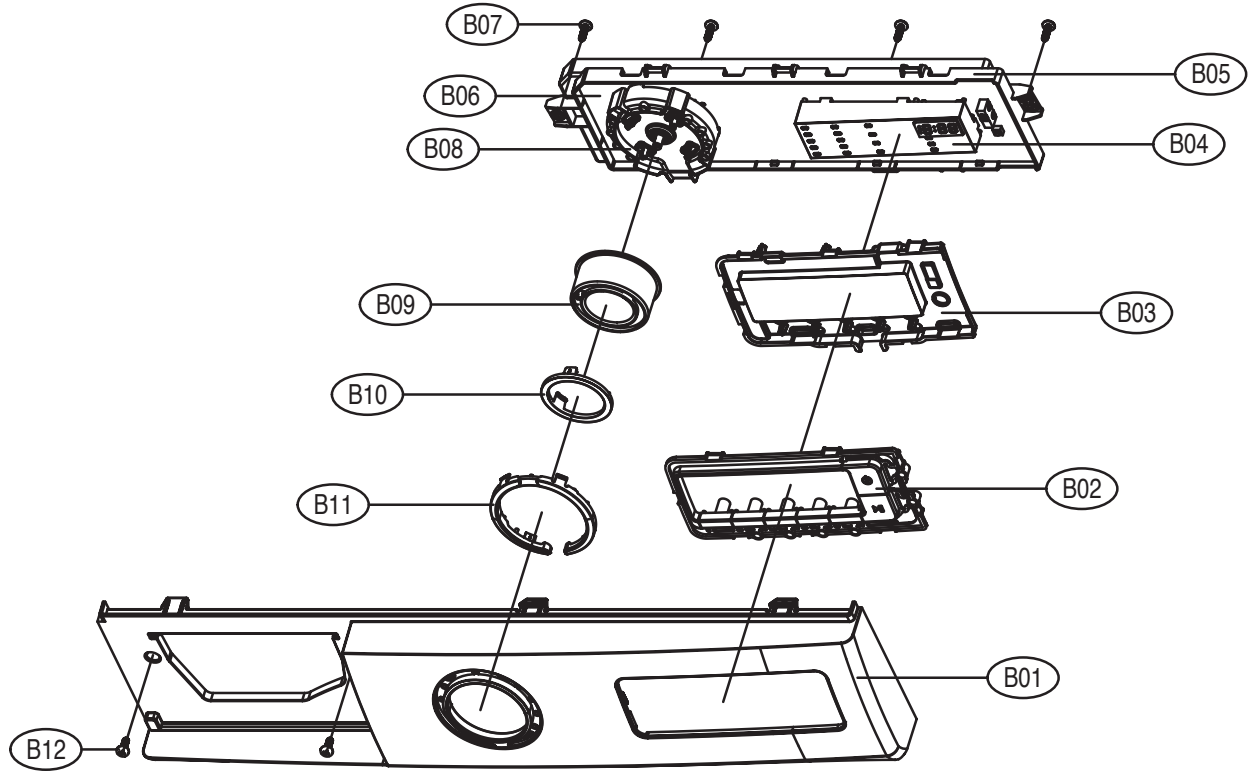

No.	PART NAME	PART CODE	SPECIFICATION	Q'TY	REMARK
B01	PANEL F	36142T3100	D-F'SERIES 7TH , ABS	1	DWD-FT1X71(2)
		36142T3110	D-F'SERIES 7TH , ABS+ SPRAY		DWD-FT1X73
B02	BUTTON SELECT	3616646100	D-F'SERIES 7TH , ABS(SPRAY)	1	DWD-FT1X7X
B03	WINDOW DISPLAY	3615510500	D-F'SERIES 7TH , TR ABS	1	DWD-FT1X7X
B04	HOLDER LED(FUNCTION)	3613062200	D-F'SERIES 7TH ,HIPS	1	DWD-FT1X7X
B05	CASE PCB	3611149700	D-F'SERIES 6TH / 7TH, HIPS	1	DWD-FT1X6(7)X
B06	PCB AS	PRPSSWB---	D-FT1X7X SERIES	1	Refer to Detailed Part Code of PCB AS
B07	SCREW TAPPING	7122401611	T2S TRS 4x16 MFZN	4	
B08	HOLDER LED COURSE	3613062100	D-F'SERIES 7TH , HIPS	1	DWD-FT1X7X
B09	BUTTON DIAL	3616646000	D-F'SERIES 7TH . ABS	1	DWD-FT1X71(2)
		3616646010	D-F'SERIES 7TH . ABS+ SPRAY		DWD-FT1X73
B10	DECO KNOB DIAL	3611696400	L-SERIES 2ND,ABS,SPIN	1	DWD-FT1X7X
B11	WINDOW COURSE	3615510600	D-F'SERIES 7TH , TR ABS	1	DWD-FT1X7X
B12	SCREW TAPPING	7122401608	T2S TRS 4x16 SUS	2	

■ PANEL FRONT AS (DWD-FC1X8X SERIES)

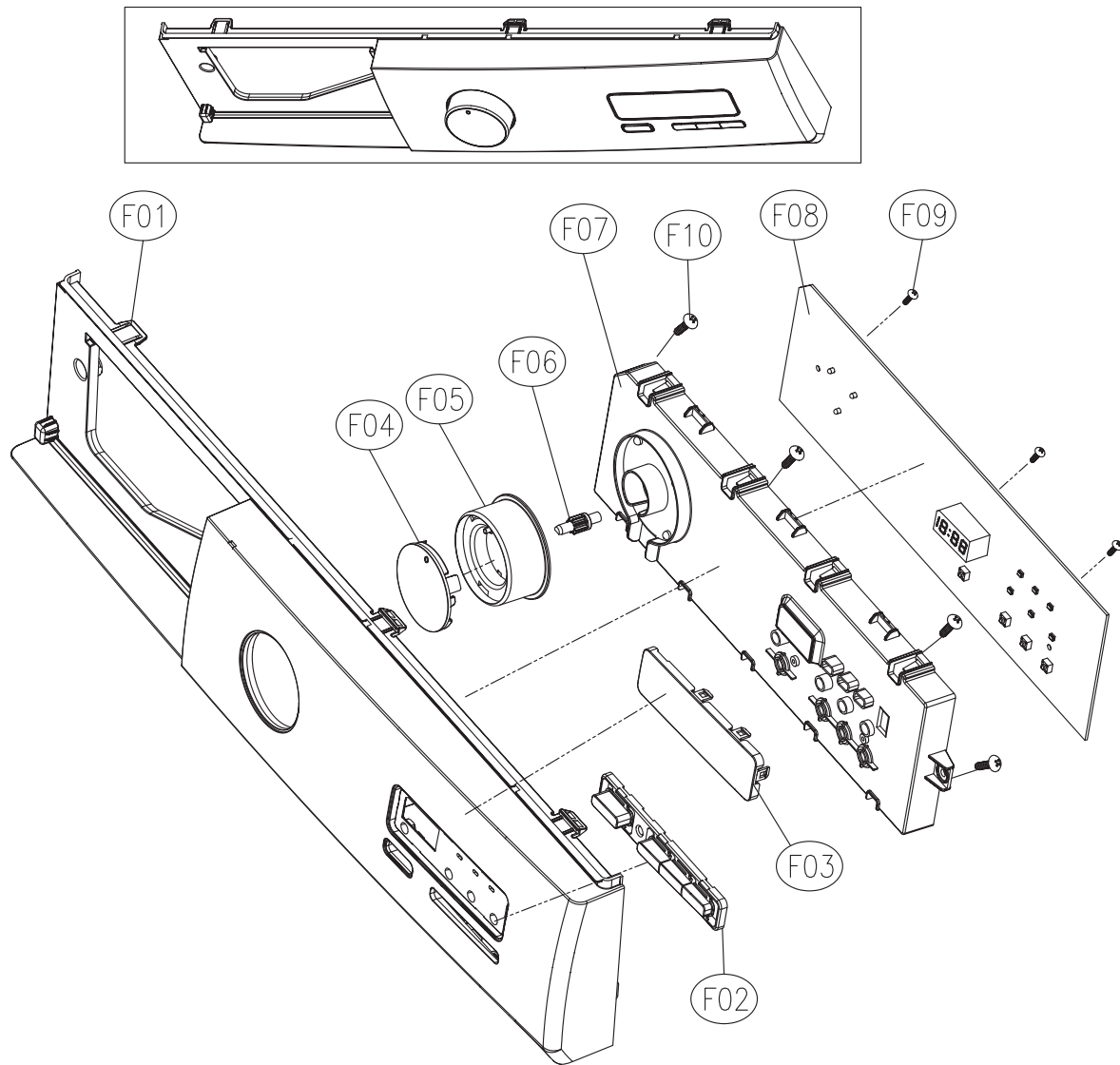

No.	PART NAME	PART CODE	SPECIFICATION	Q'TY	REMARK
F01	PANEL F	36142T3A00	HIPS, FT1081	1	
F02	BUTTON P.S	3616647600	ABS, FT1081	1	
F03	WINDOW DISPLAY	3615511700	ABS(TR), FT1081	1	
F04	DECO DIAL	36166DGQ00	ABS, FT1081	1	
F05	KNOB DIAL	3616647700	ABS, FT1081	1	
F06	SHAFT KNOB	3614905700	POM, MU802'S	1	
F07	CASE PCB F	36111T2X00	HIPS, FT1081	1	
F08	PCB DEFAULT AS	PRPSSWB---	DWD-F1XXX SERIES	1	Refer to Detailed Part Code of PCB AS
F09	SCREW TAPPING	7122300811	T2S TRS 3X8	3	
F10	SCREW TAPPING	7122401411	T2S TRS 4X14	4	

■ PANEL FRONT AS (DWD-FC1X9X SERIES)

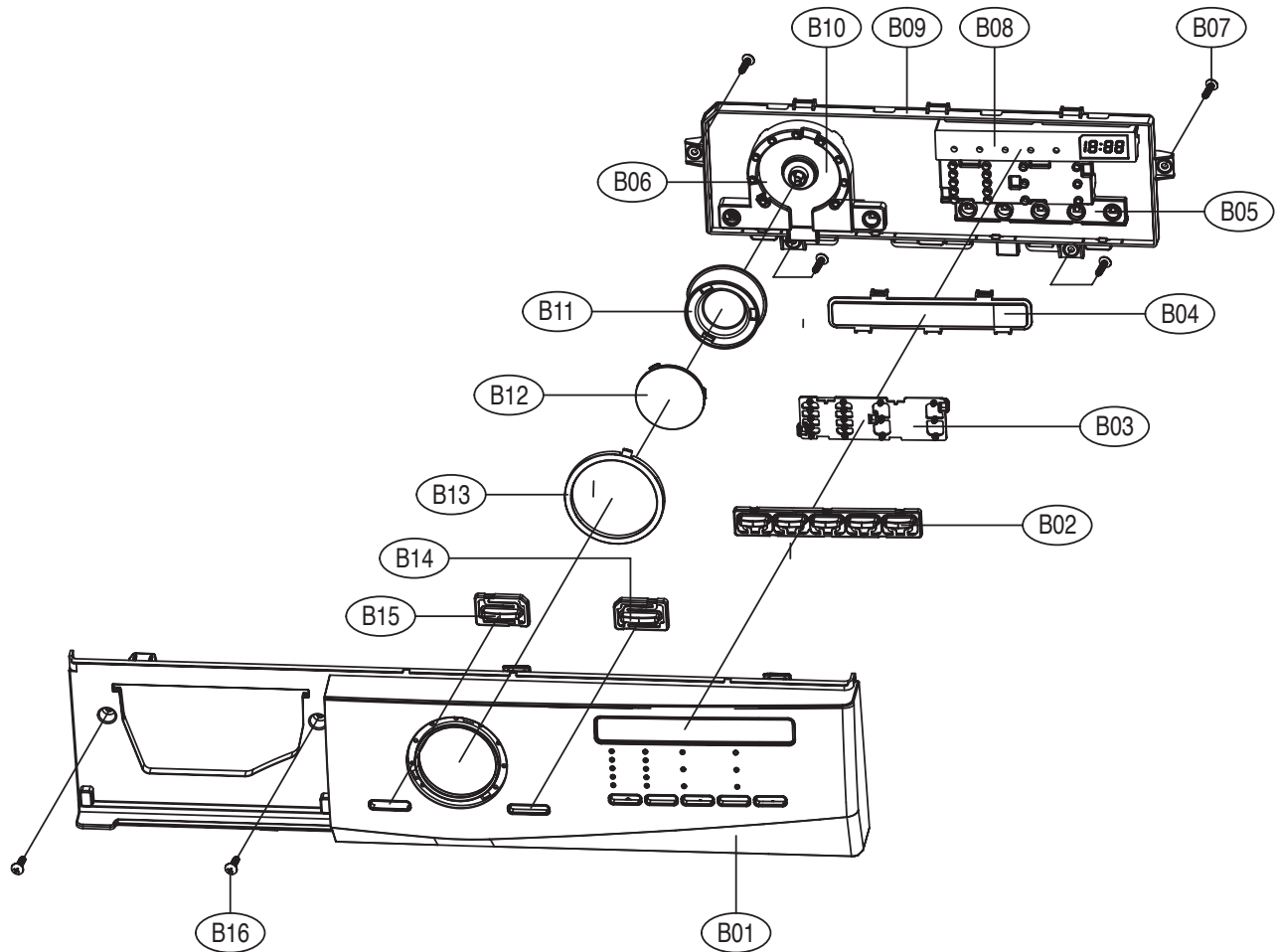

No.	PART NAME	PART CODE	SPECIFICATION	Q'TY	REMARK
F01	PANEL F	36142T4A00	ABS	1	
F02	BUTTON FUNCTION	3616649300	ABS	1	
F03	WINDOW FUNCTION	3615512300	TR-ABS(MILKY)	1	
F04	WINDOW DISPLAY	3615512200	TR-ABS	1	
F05	HOLDER LED FUNCTION	3613065500	HIPS	1	
F06	PCB AS	PRPSSW----	DWD-FD149'S	1	
F07	SCREW TAPPING	7122401611	T2S TRS 4x16 MFZN	4	
F08	DECORATOR FILM	36116DWH00	P.C FILM	1	
F09	CASE PCB	36111T3B00	HIPS	1	
F10	HOLDER LED COURSE	3613065400	HIPS	1	
F11	KNOB DIAL	3613409600	ABS	1	
F12	DECORATOR DIAL	36116DWG00	ABS	1	
F13	WINDOW COURSE	3615512400	TR-ABS	1	
F14	BUTTON START	3616649200	ABS	1	
F15	BUTTON POWER	3616649100	ABS	1	
F16	SCREW TAPPING	7122401611	T2S TRS 4x16 SUS	2	

■ CABINET FRONT AS

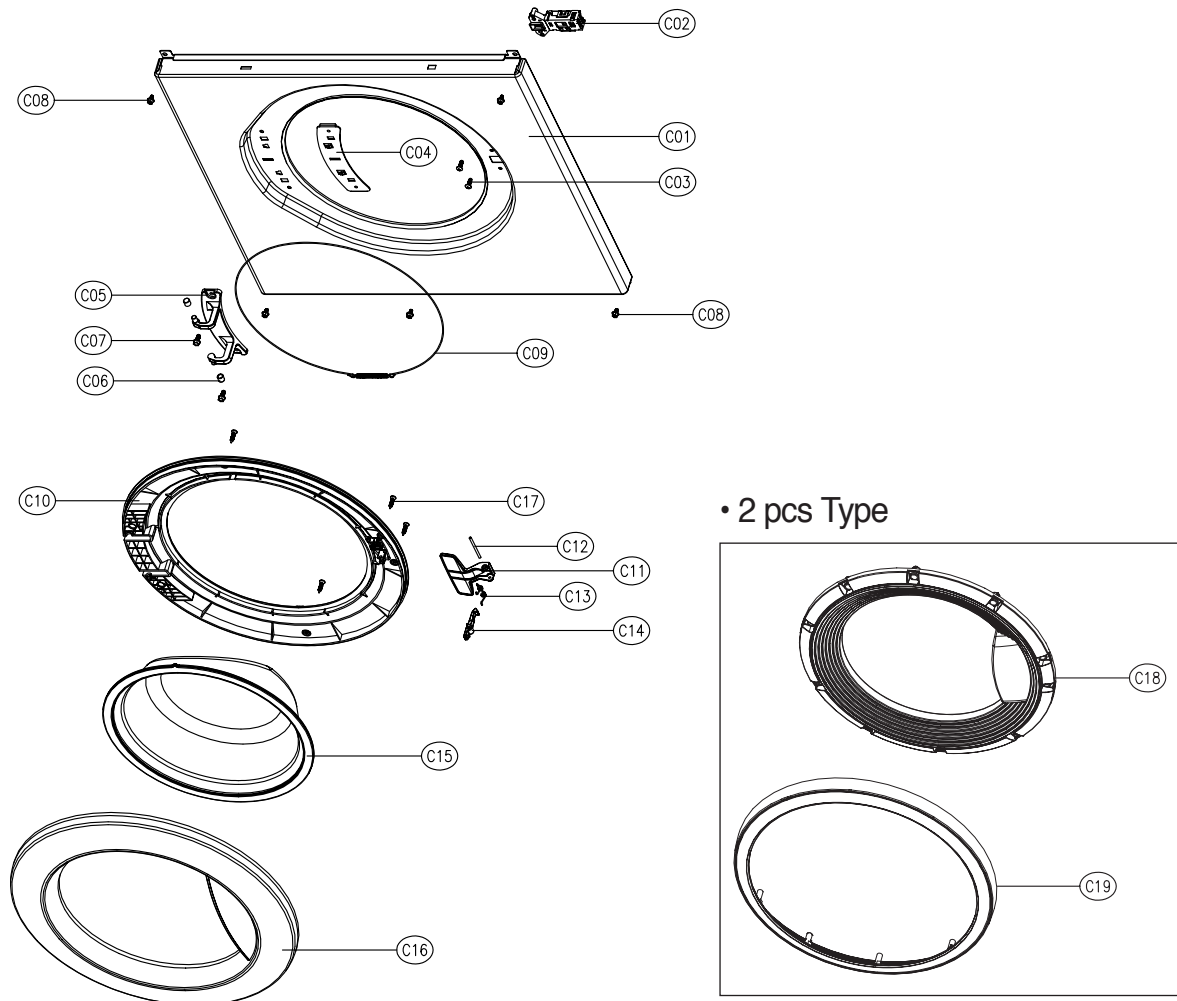

• 2 pcs Type

No.	PART NAME	PART CODE	SPECIFICATION	Q'TY	REMARK
C01	CABINET FRONT	3610811210	PCM, SGCC 0.8T, SILVER	1	DWD-FT1XX3
		3610811220	SECD 0.7T		DWD-FT1XX1(2)
C02	SWITCH DOOR LOCK	3619047100	DL-LC.BITRON_3P.250V16A.BI-METAL	1	
C03	SCREW TAPPING	7122401208	T2S TRS 4X12 SUS	2	
C04	PLATE HINGE SUPPORT	3614531900	SGCC T1.6	0	No use
C05	HINGE DOOR	3612902800	ALDC	1	
C06	CAP HINGE DOOR	3610916500	POM	2	
C07	SCREW TAPPING	3616030000	F/L BOLT(SE) 5*12 SUS	2	
C08	SCREW TAPPING	3616029950	TTS"S" HEX F/L 4*8	6	
C09	CLAMP DOOR AS	3611204810	HSW3, D=1.4 GS	1	
C10	FRAME DOOR I	3612205200	PP	1	
C11	HANDLE DOOR	3612608600	ABS	1	
C12	PIN HANDLE	3618200200	SUS304, D3, L48	1	
C13	SPRING HOOK	3615114600	SUS D1.4	1	
C14	HOOK DOOR	3613100700	ZNDC	1	
C15	DOOR GLASS	361A110700	GLASS PI300	1	
C16	FRAME DOOR O	3612205102	HIPS D-F'S		DWD-FT1XX1
		3612205120	CR3		DWD-FT1XX2(3)
C17	SCREW TAPPING	7115402008	T1S FLT 4*20 SUS	6	
C18	FRAME DOOR O	3612211900	D-F'S, 2 PCS TYPE, ABS, BLACK	1	2 pcs type(option)
		3612211910	D-F'S, 2 PCS TYPE, HIPS, WHITE		
C19	DECO DOOR O	3612212000	D-F'SERIES 6&7TH, ABS	1	

■ TUB ASS'Y

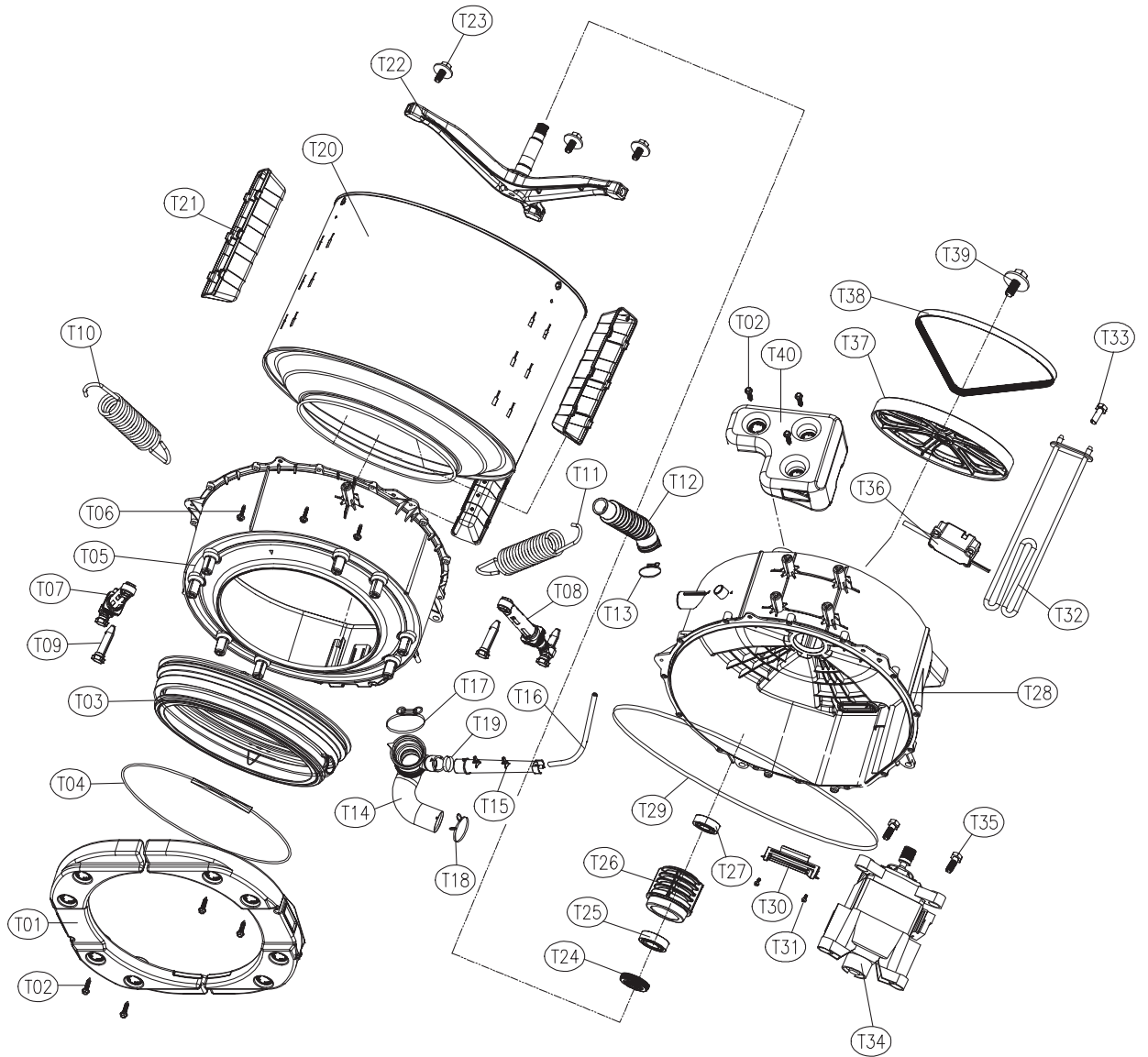

No.	PART NAME	PART CODE	SPECIFICATION	Q'TY	REMARK
T01	BALANCER WEIGHT F L/R	3616106330	D-FC/FB 공용	2	6.5 kg (L,R 2EA, FD's)
T02	SPECIAL SCREW	3616029400	SWCH 8.5X30	11	B/W Front / B/W Top
T03	GASKET	3612327300	EPDM, D-FT1081	1	
T04	CLAMP GASKET AS	3611204520	HSW3, GS	1	
T05	TUB *F	3618831000	FRPP, FT1081	1	
T06	SPECIAL SCREW	3616062700	SWRCH 18A 5.6X30	12	
T07	DAMPER FRICTION	361A700140	70N CIMA ST=170-260 DL=202	1	
T08	DAMPER FRICTION	361A700140	70N CIMA ST=170-260 DL=202	1	
T09	DAMPER PIN	361A700200	AKS D=14.5	2	
T10	SPRING SUSPENSION L	3615118710	FU1081, D=3.2 L=165 K=0.664	1	
T11	SPRING SUSPENSION R	3615118760	FU1081, D=3.2 L=159 K=0.455	1	
T12	HOSE VENT	3613267100	EPDM	1	
T13	CLAMP HOSE	3611204700	D26	1	
T14	HOSE DRAIN	3613267300	EPDM	1	
T15	AIR TRAP	361A500101	PP	1	
T16	HOSE AIR	3613268600	ID=4,OD=8, L=580	1	
T17	CLAMP AS	3611203210	ID=61, WIRE+GUIDE+BOLT, GS	1	
T18	CLAMP HOSE	3611201401	HSW3,YW,D2.6,ID36,W44.5	1	
T19	CLAMP HOSE	3611204700	D26	1	
T20	DRUM SUB AS	3617004002	D-F 0.4T(CENTER, REAR), 0.5(FRONT)	1	
T21	LIFTER WASH	361A400410	PP D-F'S NANO	3	
T22	SPIDER AS	361A301500	D-FT1081	1	
T23	SPECIAL SCREW	3616029500	SUS430 8*25	3	
T24	WATER SEAL	361A600100	NBR	1	1 piece SVC part
T25	BEARING INNER	3616303100	F,L,E,U,6206Z	1	
T26	BEARING HOUSING	3616305600	ALDC, FT1081	1	
T27	BEARING OUTER	3616303200	F,L,E,U,6205Z	1	
T28	TUB REAR	3618831100	FRPP, FT1081	1	
T29	SEALING TUB	3612321601	EPDM L1600(-0~ +10)	1	
T30	FIXTURE HEATER	3612007300	SUS 0.7T 440X45	1	
T31	SCREW TAPPING	7122401408	T2S TRS 4*14 SUS,STS	2	
T32	HEATER WASH	3612803600	230V 2000W.1R5A721001.IRCA FUSE 2EA	1	CE, CB Standard
		3612803700	230V 2000W.1R5A721002.IRCA FUSE 2EA	1	
		3612803800	240V 2000W.1R5A721003.IRCA FUSE 2EA	1	
		3612802400	220V 2KW.1R0A721001.RW8TF.IRCA	1	
		3612802420	240V 2KW.1R0A721003.RW8TF.IRCA	1	
T33	THERMISTOR WASH	361AAAAB10	R25=1.704_ R80=11.981_	1	
T34	UNIT MOTOR UNIVERSAL	36189L4H30	DC220V 50HZ 2P PI340 45T DUM-66 TONLON	1	
		36189L4H10	AC220~240/50 G&J GJ-2UA005A 2P PI340 45T(CCA)	1	option
		36189L4H20	DC220/50 C&M 2P PI340 45T(AL)	1	option
T35	SPECIAL SCREW	3616007400	T2S TRS 4X10+24	2	
T36	UNIT BUBBLE PUMP AS	36189L4120	220-240V DBK-240DB RP CHSHION	1	
T37	PULLEY	3618433200	ALDC, D-FU		
T38	BELT V	3616591110	GATES 4PJ1120 BUTADIENE RUBBER	1	
T39	SPECIAL BOLT AS	3616029600	SWCH 10*30,F/L BOLT S.P/W SEAL LOCK	1	
T40	BALANCER WEIGHT TOP	3616112800	D-FC's, 6Kg	1	신작 부품 적용. 금형 신작

■ CABINET AS

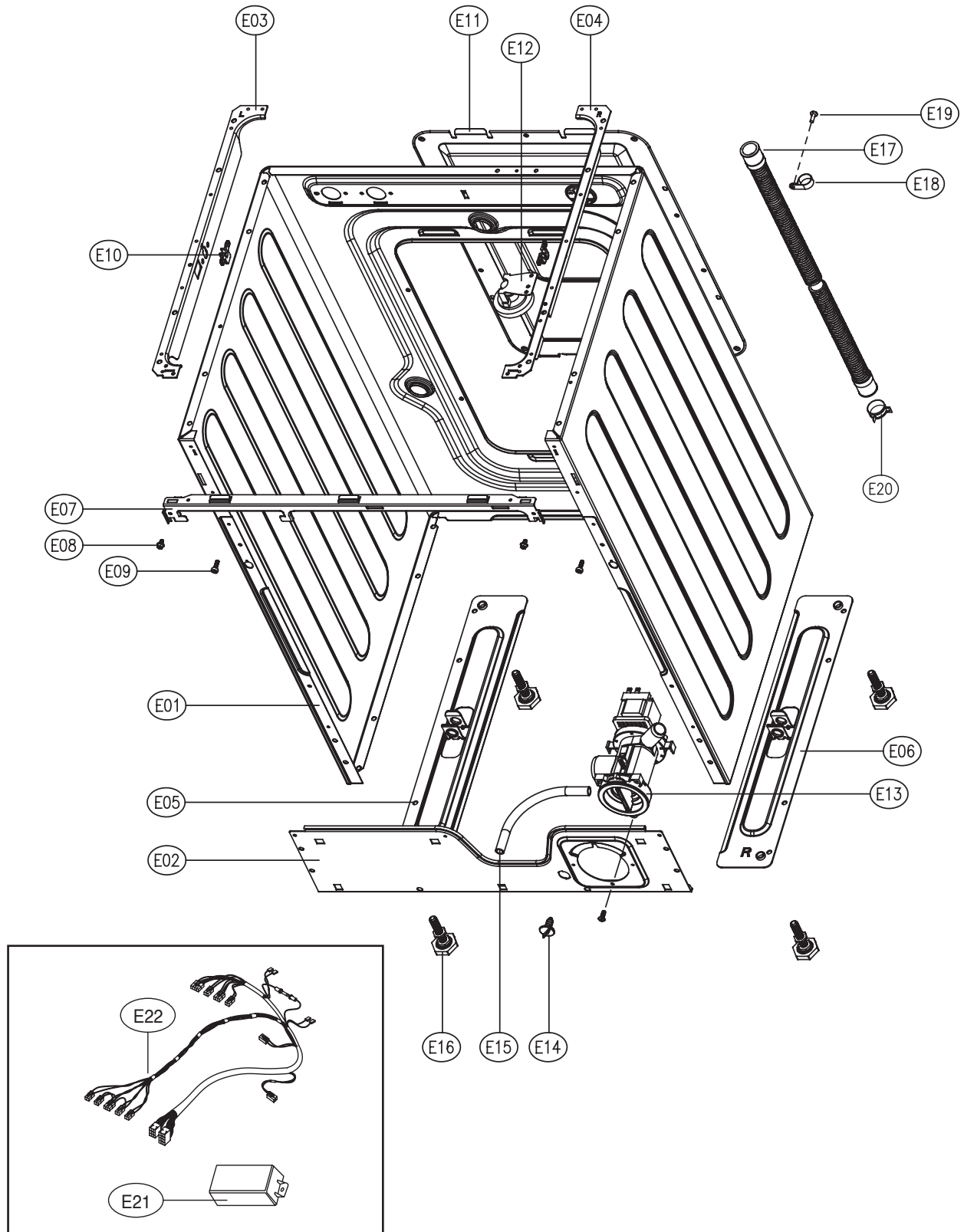

No.	PART NAME	PART CODE	SPECIFICATION	Q'TY	REMARK
E01	CABINET	3610811101	SGCC(GI), 0.7TX825.7X1630.8	1	1 piece SVC part
E02	FRAME LOWER	3612205501	SGCC T1.0 160X580	1	
E03	FRAME TOP *L	36122UDY00	SGCC T=1.2, FT1081	1	
E04	FRAME TOP *R	36122UDZ00	SGCC T=1.2, FT1081	1	
E05	BASE UNDER *L	3610392201	SGCC T1.4 100x500	1	
E06	BASE UNDER *R	3610392301	SGCC T1.4 100x500	1	
E07	FRAME UPPER	3612205801	SGCC T1.0 580X55	1	DWD-FT1*1*~1*7*
		36122UE000	SGCC1.0T , FT1081	1	DWD-FT1*8*
E08	SCREW TAPPING	3616029950	TTS"S" HEX F/L 4X8	4	
E09	SPECIAL BOLT	3616029100	M4x12.5, MACHINE	2	
E10	STOPPER SPRING	3615202200	POM	2	
E11	COVER BACK AS	3611425520	COVER BACK+CUSHION	1	
E12	SENSOR PRESSURE	3614825330	DL-DW11-H AIR INLET 90 HOOK TYPE	1	
E13	UNIT DRAIN PUMP AS	36189L5K20	AL.220-240/50 B20-6 30W 6KG	1	220-240V 50Hz
		36189L5J20	AL.220/60 B20-5 35W 6KG	1	220V 60Hz
E14	CAP WATER REMAIN	3610916800	PP	1	
E15	HOSE WATER REMAIN	3613268700	EPDM, ID8.5, L200	1	
E16	LEG ADJUST AS	3617703811	CHINA PARTS, DWD-900W	4	
E17	HOSE DRAIN OUTER AS	361327492T	D-F'S L1960, EXPORT GENERAL	1	
E18	CLAMP HOSE	3611206410	NYLON, DA-16N, ID21.9 D-MU80	1	
E19	SCREW TAPPING	7122401411	T2S TRS 4*14 MFZN	1	
E20	CLAMP HOSE	3611204701	D26	1	
E21	EMI FILTER	3611908810	D-FT1081, 2X0.47UP(X2), 2X1500PF(Y2), 1X471K(Z1)	1	
E22	HARNESS AS	3612794304	D-FU NEW EMI NON HOT/NON BUBBLE	1	

■ PLATE T AS + PANEL LOWER AS

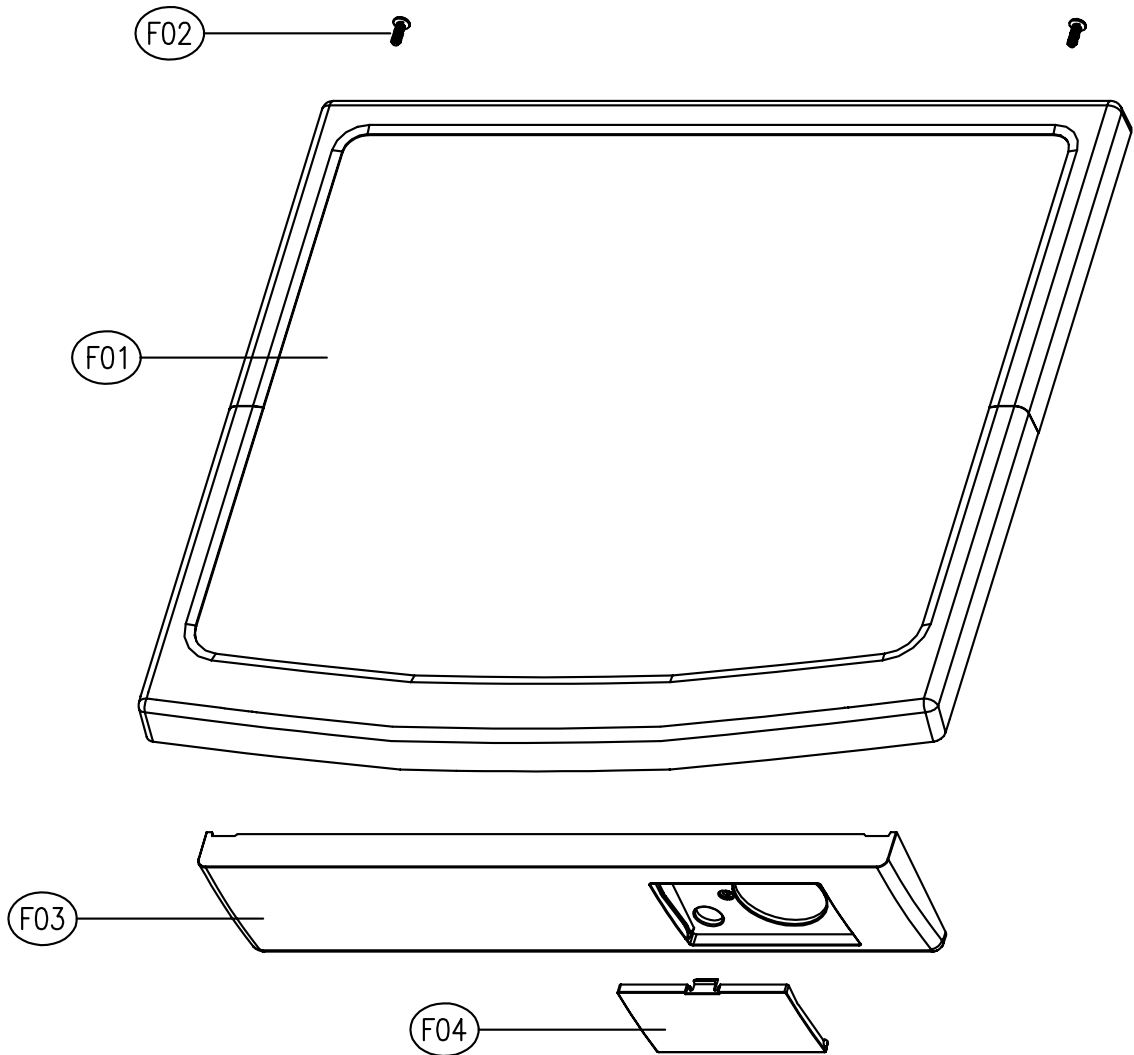





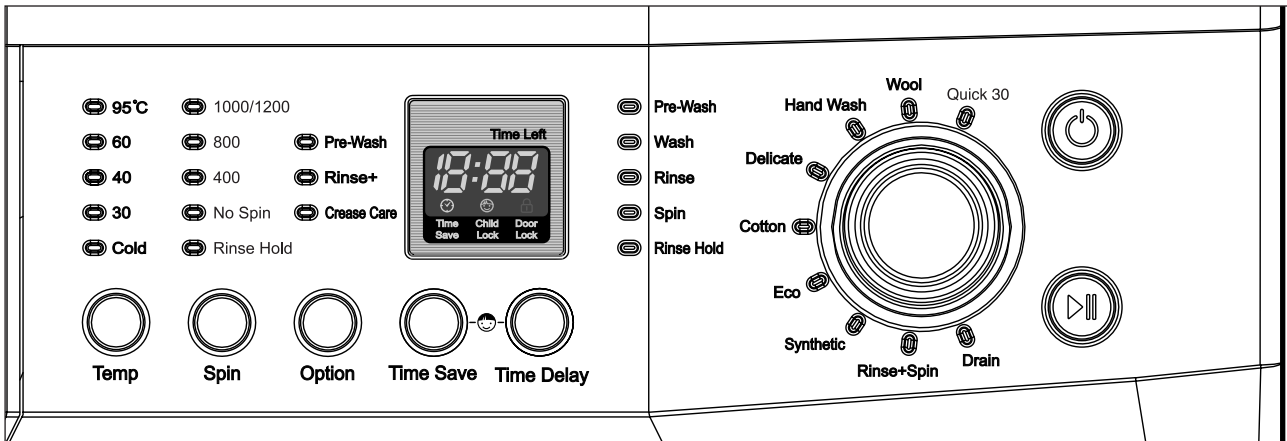

No.	PART NAME	PART CODE	SPECIFICATION	Q'TY	REMARK
F01	PLATE TOP AS	3614532900	DWD-800W(HIPS, MFC, WH)	1	DWD-F1X11(2)
		3614532910	ABS+UV SPRAY, MFC, SILVER		DWD-F1X13
		3614532920	DWD-F1X2X(HIPS, MFC, WH)		DWD-F1X21(2)
		3614532930	ABS+UV SPRAY, MFC, SILVER		DWD-F1X23
		3614533300	FX1X31~2, 41~2(HIPS, MFC, WH)		DWD-F1X31(2)
					DWD-F1X41(2)
					DWD-F1X51(2)
		DWD-F1X61(2)			
		DWD-F1X71(2)			
		3614533310	F3~F4'S, SPRAY(ABS, MFC, SILVER)		DWD-F1X33
					DWD-F1X43
					DWD-F1X53
					DWD-F1X63
					DWD-F1X73
F02	SCREW TAPPING	7122401411	T2S TRS 4x14 MFZN	2	
F03	PANEL LOWER	3614282801	HIPS	1	
F04	COVER PUMP FILTER	3611425801	HIPS	1	

6. FUNCTIONS OF THE CONTROL PANEL

■ DWD-FC1X1X SERIES





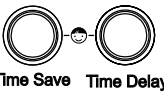
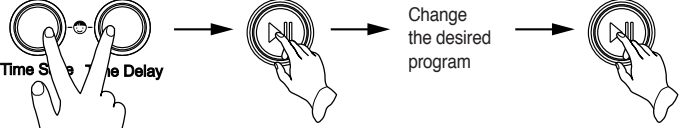
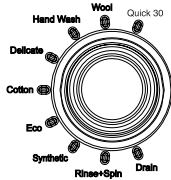

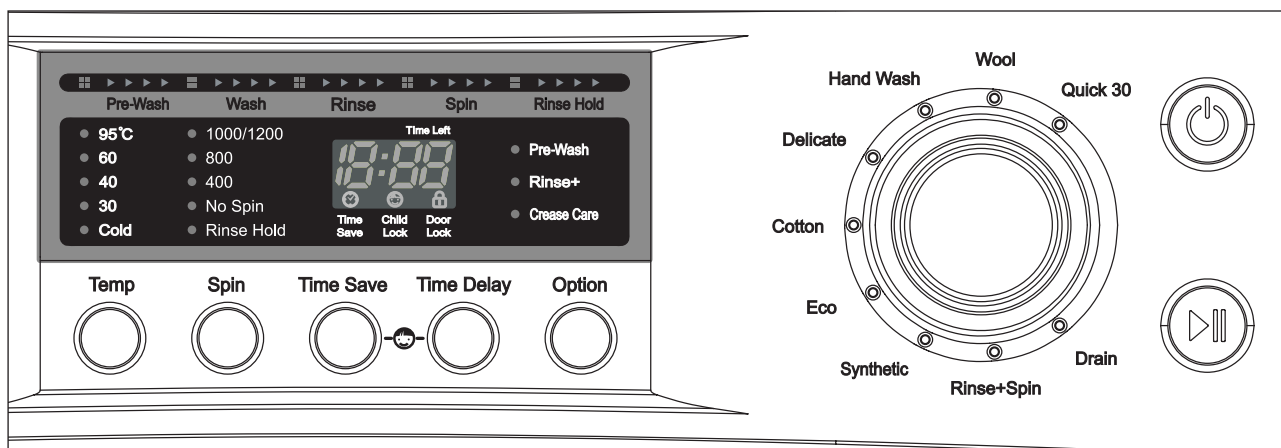

	<p>Power Button Press this button to turn the power ON or OFF.</p>
	<p>Start/Hold Button This button is use to start wash cycle or stop temporarily. When you want to change program in operating, press this button.</p>
 Temp	<p>Temperature Button This button can be used to adjust temperature of water according to types of the load to be washed.</p>
 Spin	<p>Spin Speed Button By pressing this button, the spin speed can be chosen.</p> <p>Rinse Hold This function leaves clothes in the machine suspended in the water after a rinse without entering into spin.</p> <p>Spin only If you want only spin, you can operate spin only.</p>
 Option	<p>Option Button By pressing this button, all option functions may be selected.</p> <p>Pre-Wash If the laundry is heavily soiled, Pre-Wash course is effective. Pre-Wash is available in Cotton and Synthetic.</p> <p>Rinse+ By selecting Rinse+ function, the rinse time and the rinse water are increased.</p> <p>Crease Care If you want to prevent crease, select this button with spin speed.</p>

 <p>Time Save</p>	<p>Time Save Button</p> <p>By pressing this button, you can decrease pre-set washing time to 10 minutes. Time save is available in Cotton, Eco and Synthetic.</p>
 <p>Time Delay</p>	<p>Time Delay Button</p> <p>If you want to reserve the finishing time of washing, use this button. If the Time Delay button is pressed, "2:00" is displayed. The maximum delayed time is 12:00 hours and the minimum time is 2:00 hours. Each pressing of the button advances on time delay by one hour.</p>
 <p>Time Save Time Delay</p>	<p>Child Lock Button</p> <p>If you want to protect any accident occurring from handling of washer by a child, use this function. Child Lock can be set by pressing "Time Save" and "Time Delay" buttons simultaneously during 2~3seconds.</p> <p><i>*When Child Lock is set, no button functions except Power button.</i> To cancel Child Lock, press "Time Save" and "Time Delay" buttons simultaneously again.</p> <p>To change to the desired program, while in child lock mode.</p> <ol style="list-style-type: none"> 1. Press both "Time Save" and "Time Delay" buttons together once again. 2. Press the Start/Hold button. 3. Select the desired program and press the Start/Hold button again. 
	<p>Program Dial</p> <p>When Start/Hold button is pressed, the Cotton program is automatically selected. By turning the Program Dial, the program is selected in order of "Cotton↔Delicate↔Hand Wash↔Wool↔Quick 30↔Drain↔Rinse+Spin↔Synthetic↔Eco"</p>

■ DWD-FC1X2X SERIES





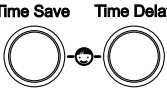
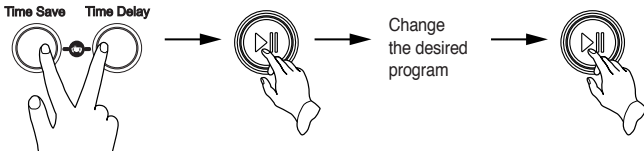
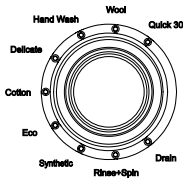

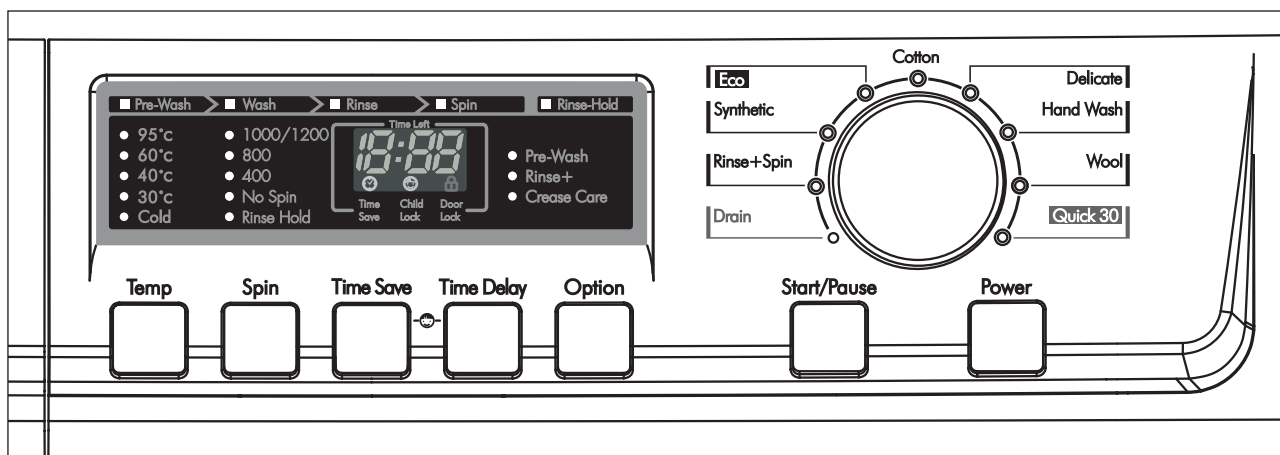

	<p>Power Button Press this button to turn the power ON or OFF.</p>
	<p>Start/Hold Button This button is use to start wash cycle or stop temporarily. When you want to change program in operating, press this button.</p>
<p>Temp</p> 	<p>Temperature Button This button can be used to adjust temperature of water according to types of the load to be washed.</p>
<p>Spin</p> 	<p>Spin Speed Button By pressing this button, the spin speed can be chosen.</p> <p>Rinse Hold This function leaves clothes in the machine suspended in the water after a rinse without entering into spin.</p> <p>Spin only If you want only spin, you can operate spin only.</p>
<p>Option</p> 	<p>Option Button By pressing this button, all option functions may be selected.</p> <p>Pre-Wash If the laundry is heavily soiled, Pre-Wash course is effective. Pre-Wash is available in Cotton and Synthetic.</p> <p>Rinse+ By selecting Rinse+ function, the rinse time and the rinse water are increased.</p> <p>Crease Care If you want to prevent crease, select this button with spin speed.</p>

<p>Time Save</p> 	<p>Time Save Button</p> <p>By pressing this button, you can decrease pre-set washing time to 10 minutes. Time save is available in Cotton, Eco and Synthetic.</p>
<p>Time Delay</p> 	<p>Time Delay Button</p> <p>If you want to reserve the finishing time of washing, use this button. If the Time Delay button is pressed, "2:00" is displayed. The maximum delayed time is 12:00 hours and the minimum time is 2:00 hours. Each pressing of the button advances on time delay by one hour.</p>
<p>Time Save Time Delay</p> 	<p>Child Lock Button</p> <p>If you want to protect any accident occurring from handling of washer by a child, use this function.</p> <p>Child Lock can be set by pressing "Time Save" and "Time Delay" buttons simultaneously during 2~3seconds.</p> <p><i>*When Child Lock is set, no button functions except Power button. To cancel Child Lock, press "Time Save" and "Time Delay" buttons simultaneously again.</i></p> <p>To change to the desired program, while in child lock mode.</p> <ol style="list-style-type: none"> 1. Press both "Time Save" and "Time Delay" buttons together once again. 2. Press the Start/Hold button. 3. Select the desired program and press the Start/Hold button again. 
	<p>Program Dial</p> <p>When Start/Hold button is pressed, the Cotton program is automatically selected. By turning the Program Dial, the program is selected in order of "Cotton↔Delicate ↔Hand Wash↔Wool↔Quick 30↔Drain↔Rinse+Spin↔Synthetic↔Eco"</p>

■ DWD-FC1X3X SERIES





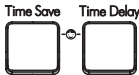
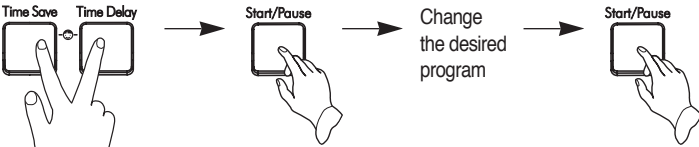
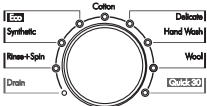



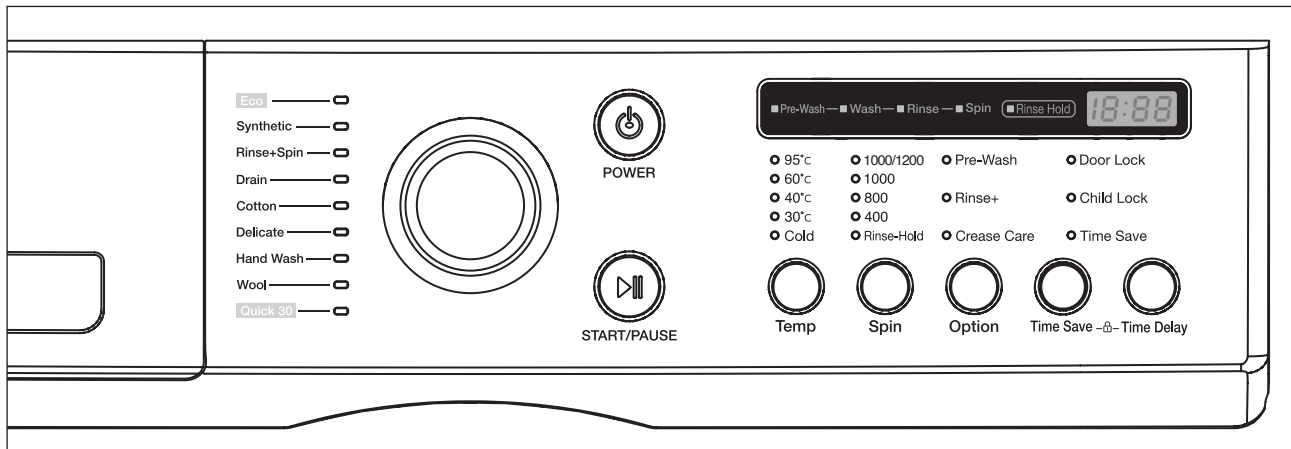

<p>Power</p> 	<p>Power Button Press this button to turn the power ON or OFF.</p>
<p>Start/Pause</p> 	<p>Start/Pause Button This button is use to start wash cycle or stop temporarily. When you want to change program in operating, press this button.</p>
<p>Temp</p> 	<p>Temperature Button This button can be used to adjust temperature of water according to types of the load to be washed.</p>
<p>Spin</p> 	<p>Spin Speed Button By pressing this button, the spin speed can be chosen. Rinse Hold This function leaves clothes in the machine suspended in the water after a rinse without entering into spin. Spin only If you want only spin, you can operate spin only.</p>
<p>Option</p> 	<p>Option Button By pressing this button, all option functions may be selected. Pre-Wash If the laundry is heavily soiled, Pre-Wash course is effective. Pre-Wash is available in Cotton and Synthetic. Rinse+ By selecting Rinse+ function, the rinse time and the rinse water are increased. Crease Care If you want to prevent crease, select this button with spin speed.</p>

	<p>Time Save Button</p> <p>By pressing this button, you can decrease pre-set washing time to 10 minutes. Time save is available in Cotton, Eco and Synthetic.</p>
	<p>Time Delay Button</p> <p>If you want to reserve the finishing time of washing, use this button. If the Time Delay button is pressed, "2:00" is displayed. The maximum delayed time is 12:00 hours and the minimum time is 2:00 hours.</p> <p>Each pressing of the button advances on time delay by one hour.</p>
	<p>Child Lock Button</p> <p>If you want to protect any accident occurring from handling of washer by a child, use this function.</p> <p>Child Lock can be set by pressing "Time Save" and "Time Delay" buttons simultaneously during 2~3seconds.</p> <p><i>*When Child Lock is set, no button functions except Power button.</i></p> <p>To cancel Child Lock, press "Time Save" and "Time Delay" buttons simultaneously again.</p> <p>To change to the desired program, while in child lock mode.</p> <ol style="list-style-type: none"> 1. Press both "Time Save" and "Time Delay" buttons together once again. 2. Press the Start/Pause button. 3. Select the desired program and press the Start/Pause button again. 
	<p>Program Dial</p> <p>When Start/Pause button is pressed, the Cotton program is automatically selected.</p> <p>By turning the Program Dial, the program is selected in order of "Cotton↔Delicate↔Hand Wash↔Wool↔Quick 30↔Drain↔Rinse+Spin↔Synthetic↔Eco"</p>

■ DWD-FC1X4X SERIES





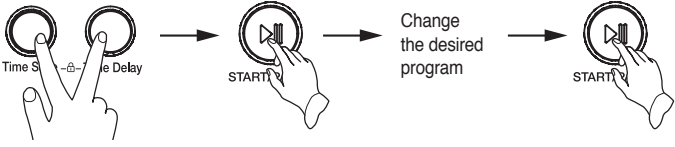
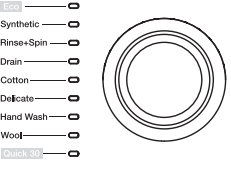

 <p>POWER</p>	<p>Power Button Press this button to turn the power ON or OFF.</p>
 <p>START/PAUSE</p>	<p>Start/Pause Button This button is use to start wash cycle or stop temporarily. When you want to change program in operating, press this button.</p>
 <p>Temp</p>	<p>Temperature Button This button can be used to adjust temperature of water according to types of the load to be washed.</p>
 <p>Spin</p>	<p>Spin Speed Button By pressing this button, the spin speed can be chosen.</p> <p>Rinse Hold This function leaves clothes in the machine suspended in the water after a rinse without entering into spin.</p> <p>Spin only If you want only spin, you can operate spin only.</p>
 <p>Option</p>	<p>Option Button By pressing this button, all option functions may be selected.</p> <p>Pre-Wash If the laundry is heavily soiled, Pre-Wash course is effective. Pre-Wash is available in Cotton and Synthetic.</p> <p>Rinse+ By selecting Rinse+ function, the rinse time and the rinse water are increased.</p> <p>Crease Care If you want to prevent crease, select this button with spin speed.</p>

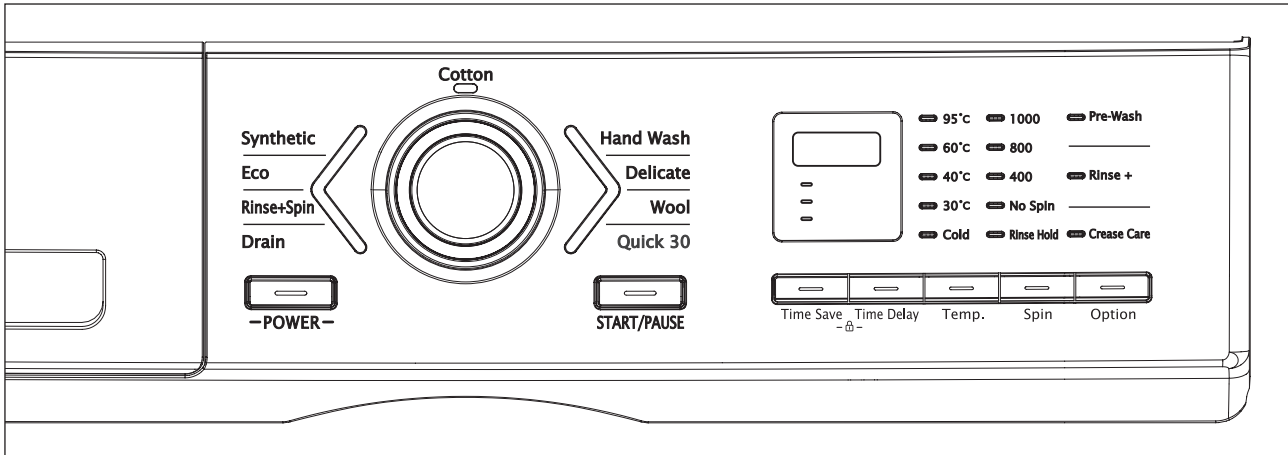
 <p>Time Save</p>	<p>Time Save Button</p> <p>By pressing this button, you can decrease pre-set washing time to 10 minutes. Time save is available in Cotton, Eco and Synthetic.</p>
 <p>Time Delay</p>	<p>Time Delay Button</p> <p>If you want to reserve the finishing time of washing, use this button. If the Time Delay button is pressed, '2:00' is displayed. The maximum delayed time is 12:00 hours and the minimum time is 2:00 hours. Each pressing of the button advances on time delay by one hour.</p>
 <p>Time Save -△- Time Delay</p>	<p>Child Lock Button</p> <p>If you want to protect any accident occurring from handling of washer by a child, use this function.</p> <p>Child Lock can be set by pressing 'Time Save' and 'Time Delay' buttons simultaneously during 2~3seconds.</p> <p><i>*When Child Lock is set, no button functions except Power button.</i></p> <p>To cancel Child Lock, press 'Time Save' and 'Time Delay' buttons simultaneously again.</p> <p>To change to the desired program, while in child lock mode.</p> <ol style="list-style-type: none"> 1. Press both 'Time Save' and 'Time Delay' buttons together once again. 2. Press the Start/Pause button. 3. Select the desired program and press the Start/Pause button again. 
 <ul style="list-style-type: none"> <input type="checkbox"/> Eco <input type="checkbox"/> Synthetic <input type="checkbox"/> Rinse+Spin <input type="checkbox"/> Drain <input type="checkbox"/> Cotton <input type="checkbox"/> Delicate <input type="checkbox"/> Hand Wash <input type="checkbox"/> Wool <input type="checkbox"/> Rinse+Spin 	<p>Program Dial</p> <p>When Start/Pause button is pressed, the Cotton program is automatically selected. By turning right the Program Dial, the program is selected in order of 'Cotton ↔ Drain ↔ Rinse+Spin ↔ Synthetic ↔ Eco ↔ Quick 30 ↔ Wool ↔ Hand Wash ↔ Delicate'</p>

■ DWD-FC1X5X SERIES

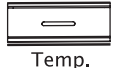



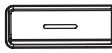
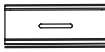
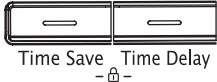
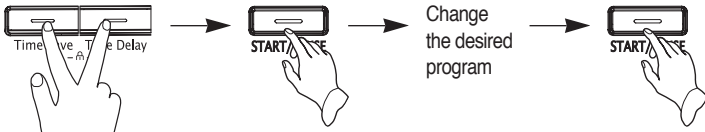
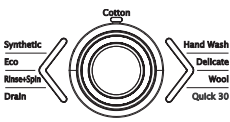



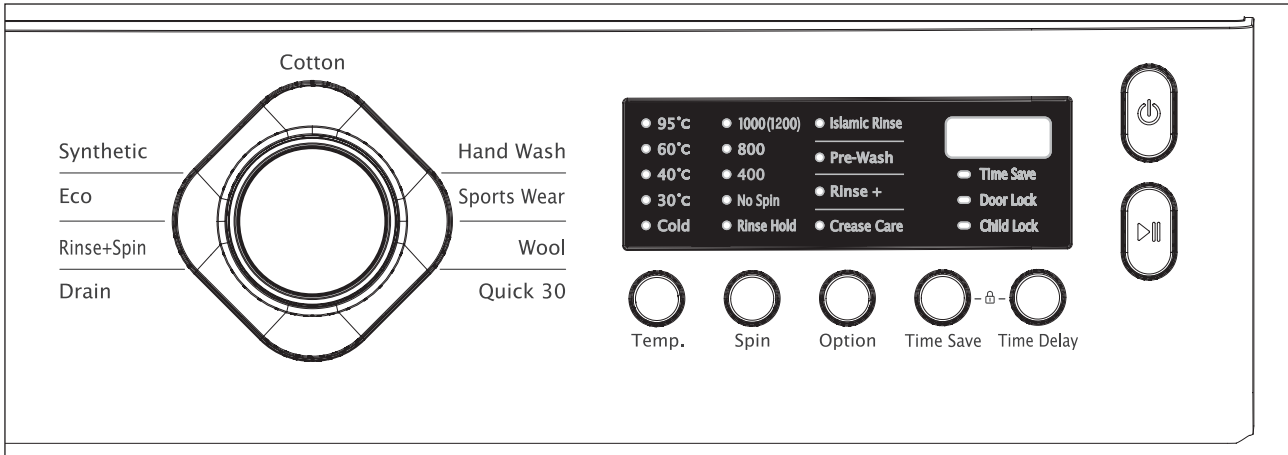

 -POWER-	<p>Power Button Press this button to turn the power ON or OFF.</p>
 START/PAUSE	<p>Start/Pause Button This button is use to start wash cycle or stop temporarily. When you want to change program in operating, press this button.</p>
 Temp.	<p>Temperature Button This button can be used to adjust temperature of water according to types of the load to be washed.</p>
 Spin	<p>Spin Speed Button By pressing this button, the spin speed can be chosen.</p> <p>Rinse Hold This function leaves clothes in the machine suspended in the water after a rinse without entering into spin.</p> <p>Spin only If you want only spin, you can operate spin only.</p>
 Option	<p>Option Button By pressing this button, all option functions may be selected.</p> <p>Pre-Wash If the laundry is heavily soiled, Pre-Wash course is effective. Pre-Wash is available in Cotton and Synthetic.</p> <p>Rinse+ By selecting Rinse+ function, the rinse time and the rinse water are increased.</p> <p>Crease Care If you want to prevent crease, select this button with spin speed.</p>

 <p>Time Save</p>	<p>Time Save Button</p> <p>By pressing this button, you can decrease pre-set washing time to 10 minutes. Time save is available in Cotton, Eco and Synthetic.</p>
 <p>Time Delay</p>	<p>Time Delay Button</p> <p>If you want to reserve the finishing time of washing, use this button. If the Time Delay button is pressed, '2:00' is displayed. The maximum delayed time is 12:00 hours and the minimum time is 2:00 hours. Each pressing of the button advances on time delay by one hour.</p>
 <p>Time Save Time Delay - -</p>	<p>Child Lock Button</p> <p>If you want to protect any accident occurring from handling of washer by a child, use this function. Child Lock can be set by pressing 'Time Save' and 'Time Delay' buttons simultaneously during 2~3seconds.</p> <p><i>* When Child Lock is set, no button functions except Power button.</i></p> <p>To cancel Child Lock, press 'Time Save' and 'Time Delay' buttons simultaneously again.</p> <p>To change to the desired program, while in child lock mode.</p> <ol style="list-style-type: none"> 1. Press both 'Time Save' and 'Time Delay' buttons together once again. 2. Press the Start/Pause button. 3. Select the desired program and press the Start/Pause button again. 
	<p>Program Dial</p> <p>When Start/Pause button is pressed, the Cotton program is automatically selected. By turning right the Program Dial, the program is selected in order of 'Cotton ↔ Hand Wash ↔ Delicate ↔ Wool ↔ Quick 30 ↔ Drain ↔ Rinse+Spin ↔ Eco ↔ Synthetic'.</p>

DWD-FC1X6X SERIES





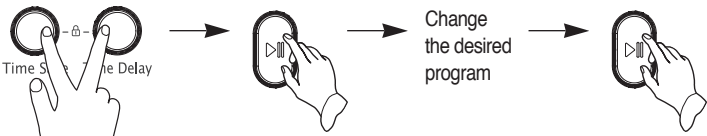
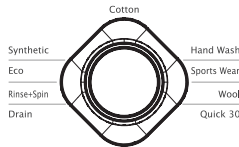



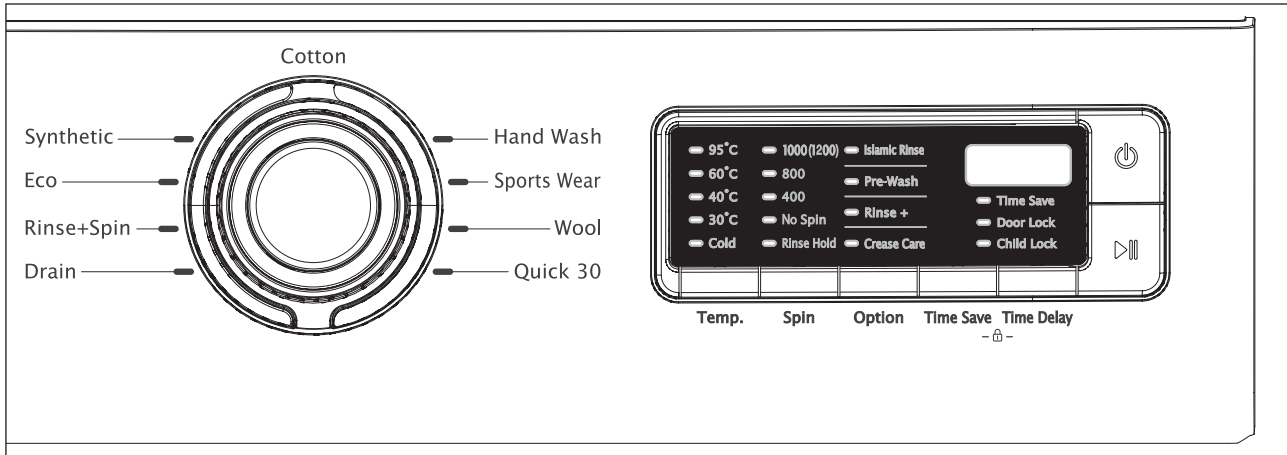

	<p>Power Button Press this button to turn the power ON or OFF.</p>
	<p>Start/Pause Button This button is use to start wash cycle or stop temporarily. When you want to change program in operating, press this button.</p>
 Temp.	<p>Temperature Button This button can be used to adjust temperature of water according to types of the load to be washed.</p>
 Spin	<p>Spin Speed Button By pressing this button, the spin speed can be chosen.</p> <p>Rinse Hold This function leaves clothes in the machine suspended in the water after a rinse without entering into spin.</p> <p>Spin only If you want only spin, you can operate spin only.</p>
 Option	<p>Option Button By pressing this button, all option functions may be selected.</p> <p>Pre-Wash If the laundry is heavily soiled, Pre-Wash course is effective. Pre-Wash is available in Cotton and Synthetic programs.</p> <p>Rinse+ By selecting Rinse+ function, the rinse time and the rinse water are increased.</p> <p>Crease Care If you want to prevent crease, select this button with spin speed.</p> <p>Islamic Rinse (Option) By selecting Islamic Rinse function, the washer operates two additional rinse times (Islamic Rinse process) after the basic rinse process. If the laundry is foamy fabric(muslim clothes, etc.), Islamic Rinse function is effective.</p> <p>Water+ (Option) If you want to use more water, press this button . By selecting Water+ option, the water add more than setting water level on rinse process.</p>

 <p>Time Save</p>	<p>Time Save Button</p> <p>By pressing this button, you can decrease pre-set washing time to 10 minutes. Time save is available in Cotton, Eco and Synthetic.</p>
 <p>Time Delay</p>	<p>Time Delay Button</p> <p>If you want to reserve the finishing time of washing, use this button. If the Time Delay button is pressed, '2:00' is displayed. The maximum delayed time is 12:00 hours and the minimum time is 2:00 hours. Each pressing of the button advances on time delay by one hour.</p>
 <p>Time Save Time Delay</p>	<p>Child Lock Button</p> <p>If you want to protect any accident occurring from handling of washer by a child, use this function.</p> <p>Child Lock can be set by pressing 'Time Save' and 'Time Delay' buttons simultaneously during 2~3seconds.</p> <p><i>* When Child Lock is set, no button functions except Power button.</i></p> <p>To cancel Child Lock, press 'Time Save' and 'Time Delay' buttons simultaneously again.</p> <p>To change to the desired program, while in child lock mode.</p> <ol style="list-style-type: none"> 1. Press both 'Time Save' and 'Time Delay' buttons together once again. 2. Press the Start/Pause button. 3. Select the desired program and press the Start/Pause button again. 
	<p>Program Dial</p> <p>When Start/Pause button is pressed, the Cotton program is automatically selected. By turning right the Program Dial, the program is selected in order of 'Cotton ↔ Hand Wash ↔ Sports Wear ↔ Wool ↔ Quick 30 ↔ Drain ↔ Rinse+Spin ↔ Eco ↔ Synthetic'.</p>

■ DWD-FC1X7X SERIES

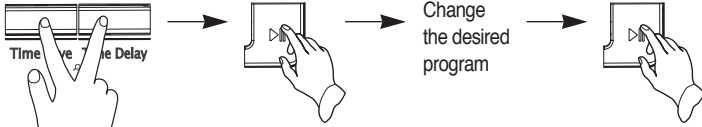
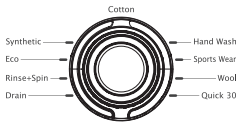

	<p>Power Button Press this button to turn the power ON or OFF.</p>
	<p>Start/Pause Button This button is use to start wash cycle or stop temporarily. When you want to change program in operating, press this button.</p>
 <p>Temp.</p>	<p>Temperature Button This button can be used to adjust temperature of water according to types of the load to be washed.</p>
 <p>Spin</p>	<p>Spin Speed Button By pressing this button, the spin speed can be chosen.</p> <p>Rinse Hold This function leaves clothes in the machine suspended in the water after a rinse without entering into spin.</p> <p>Spin only If you want only spin, you can operate spin only.</p>
 <p>Option</p>	<p>Option Button By pressing this button, all option functions may be selected.</p> <p>Pre-Wash If the laundry is heavily soiled, Pre-Wash course is effective. Pre-Wash is available in Cotton and Synthetic programs.</p> <p>Rinse+ By selecting Rinse+ function, the rinse time and the rinse water are increased.</p> <p>Crease Care If you want to prevent crease, select this button with spin speed.</p> <p>Islamic Rinse (Option) By selecting Islamic Rinse function, the washer operates two additional rinse times (Islamic Rinse process) after the basic rinse process. If the laundry is foamy fabric(muslim clothes, etc.), Islamic Rinse function is effective.</p> <p>Water+ (Option) If you want to use more water, press this button . By selecting Water+ option, the water add more than setting water level on rinse process.</p>

 <p>Time Save</p>	<p>Time Save Button</p> <p>By pressing this button, you can decrease pre-set washing time to 10 minutes. Time save is available in Cotton, Eco and Synthetic.</p>
 <p>Time Delay</p>	<p>Time Delay Button</p> <p>If you want to reserve the finishing time of washing, use this button. If the Time Delay button is pressed, '2:00' is displayed. The maximum delayed time is 12:00 hours and the minimum time is 2:00 hours. Each pressing of the button advances on time delay by one hour.</p>
 <p>Time Save Time Delay - ⏸ -</p>	<p>Child Lock Button</p> <p>If you want to protect any accident occurring from handling of washer by a child, use this function.</p> <p>Child Lock can be set by pressing 'Time Save' and 'Time Delay' buttons simultaneously during 2~3seconds.</p> <p>* <i>When Child Lock is set, no button functions except Power button.</i></p> <p>To cancel Child Lock, press 'Time Save' and 'Time Delay' buttons simultaneously again.</p> <p>To change to the desired program, while in child lock mode.</p> <ol style="list-style-type: none"> 1. Press both 'Time Save' and 'Time Delay' buttons together once again. 2. Press the Start/Pause button. 3. Select the desired program and press the Start/Pause button again. 
	<p>Program Dial</p> <p>When Start/Pause button is pressed, the Cotton program is automatically selected. By turning right the Program Dial, the program is selected in order of 'Cotton ↔ Hand Wash ↔ Sports Wear ↔ Wool ↔ Quick 30 ↔ Drain ↔ Rinse+Spin ↔ Eco ↔ Synthetic'.</p>

DWD-FC1X8X SERIES

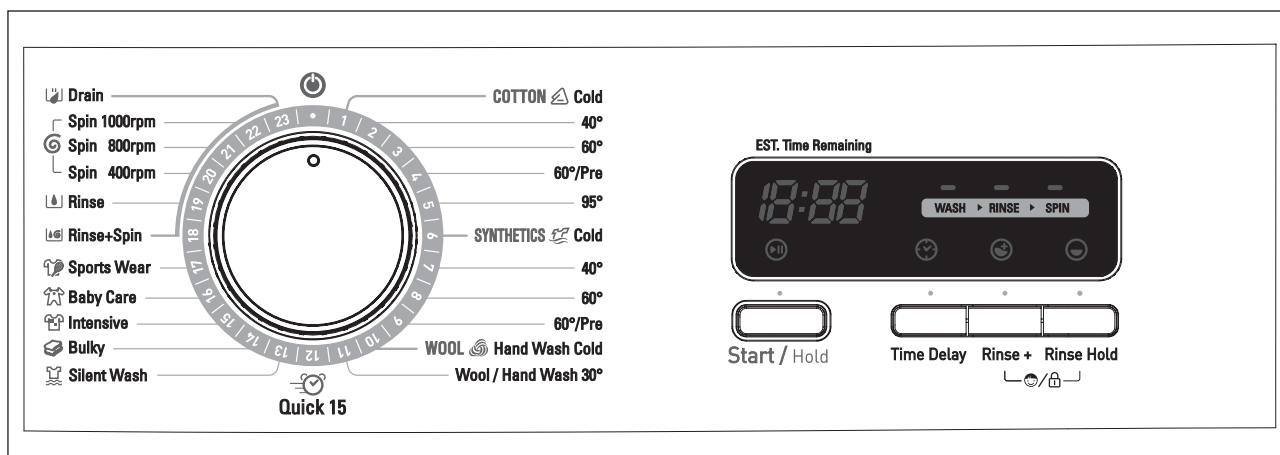

	<p>Program selector</p> <p>For switching the washing machine on and off and for selecting the programs. You can select the course you want by rotating program selector. For the more detailed information, please refer to the page 11~20. Can be rotated in both direction.</p> <p>You can turn off the power by rotating program selector to the direction at 12 o'clock.</p> <p>Even if the program selector rotates while the program is running, the program is not changed(except for off (power icon)).</p>
	<p>Operation and temporary stop is repeated as it is pressed.</p> <p>When you want to change program in operating; press the 'Start/Hold' button → select the program that you want to change → press the 'Start/Hold' button again.</p>
	<p>Rinse+</p> <ul style="list-style-type: none"> • Is used to add a rinse, which may assist in removing traces of detergent residue. • By selecting Rinse+ function, the rinse time and the rinse water are increased. • Rinse+ option is selectable with all programs except Rinse, Spin and Drain programs.
	<p>Rinse Hold</p> <ul style="list-style-type: none"> • This function leaves clothes in the machine suspended in the water after a rinse without entering into spin. • To proceed through to a drain or spin, after the Rinse Hold function is completed, use program selector(Drain or Spin program). • Rinse Hold option is selectable with all programs except Drain program.



Time Delay

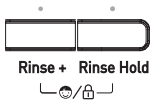

Time Delay

- It can be used to pre-engage time for wash.
- Reservation can be made from 1 hours to 12 hours.
- Time Delay function is selectable with all programs.



Rinse + Rinse Hold



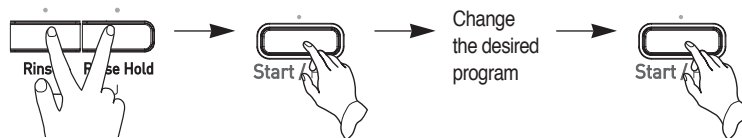

Child Lock Mode



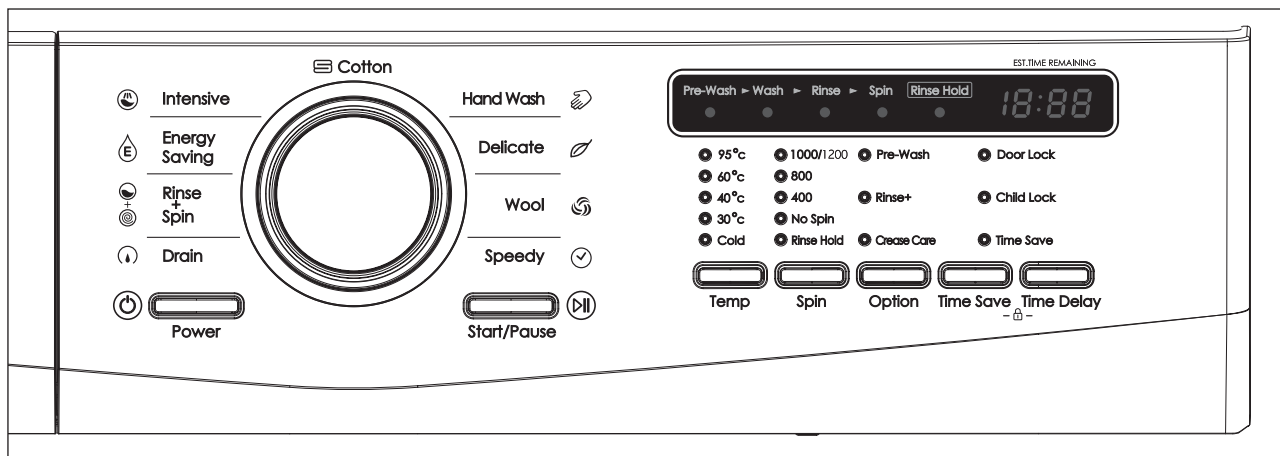

- Use this function when you want to protect any accident occurring from handling of washer by a child.
- During an operation of washer, press 'Rinse+' and 'Rinse Hold' buttons simultaneously.
- In Child Lock mode, no button functions except for off .
- In Child Lock mode, press 'Rinse+' and 'Rinse Hold' buttons simultaneously like setting Child Lock and Child Lock is cancelled.
- To change to the desired program, while in Child Lock mode;
 1. Press both the 'Rinse+' and 'Rinse Hold' buttons together once again.
 2. Press the Start/Hold button.
 3. Select the desired program and press the Start/Hold button again.
- The Child Lock will be cancelled when power is off .

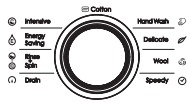

DWD-FC1X9X SERIES

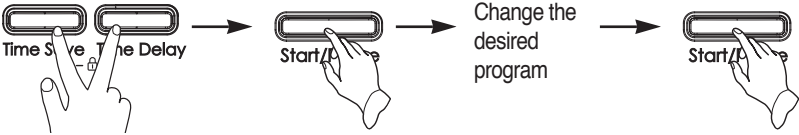

 Power	<p>Power Button Press this switch to turn the power on or off.</p>
 Start/Pause	<p>Operation and temporary stop is repeated as it is pressed. When you want to change program in operating; press the “Start/Pause” button → Select the program that you want to change → press the “Start/Pause” button again.</p>
	<p>You can select the course you want, and each lamp is turned on when that course is selected. For the more detailed information, please refer to the page 11~18.</p>
 Temp	<p>It can be used to adjust temperature of water according to types of the load to be washed. As the button is pressed, temperature of water is selected by Cold → 30°C → 40°C → 60°C → 95°C</p>
 Spin	<p>By pressing the spin button, the spin speed can be chosen.</p> <p>Rinse Hold</p> <ul style="list-style-type: none"> • Is selected by pressing the spin button repeatedly. This function leaves clothes in the machine; suspended in the water after a rinse without entering into spin. • To proceed through to a drain or spin, after the Rinse Hold function is completed, use spin button. <p>Spin only</p> <ul style="list-style-type: none"> • If you want only spin, you can operate spin only. (See page 18.)

 <p>Option</p>	<p>Crease Care • If you want to prevent crease, select this button with spin speed.</p> <p>Rinse+ • Is used to add a rinse, which may assist in removing traces of detergent residue.</p> <ul style="list-style-type: none"> • By selecting Rinse+ function, the rinse time and the rinse water are increased. <p>Pre-Wash • The washer operates one additional wash and spin before the main wash.</p> <ul style="list-style-type: none"> • If the laundry is heavily soiled, Pre-Wash course is effective. • Pre-Wash is available in Cotton and Intensive programs.
 <p>Time Save</p>	<p>All courses have pre-set washing times, but Time Save decreases it to 10 minutes. Each time this button is pressed the watch icon is repeated on and off. When it is on, the Time Save function is set. Time Save is available in Cotton, Energy Saving and Intensive programs.</p>
 <p>Time Delay</p>	<p>It can be used to pre-engage time for wash.</p>
 <p>Time Save Time Delay</p>	<p>Use this function when you want to protect any accident occurring from handling of washer by a child.</p> <p>During an operation of washer, press 'Time Save' and 'Time Delay' buttons simultaneously.</p> <p>In Child Lock mode, no button functions except Power button.</p> <p>In Child Lock mode, press 'Time Save' and 'Time Delay' buttons simultaneously like setting Child Lock and Child Lock is cancelled.</p> <p>To change to the desired program, while in Child Lock mode;</p> <ol style="list-style-type: none"> 1. Press both the Time save and Time delay buttons together once again. 2. Press the Start/Pause button. 3. Select the desired program and press the Start/Pause button again.  <p>* The Child Lock will be cancelled when power is off.</p>

7. FUNCTIONS OF THE CONTROLLER

Sequence Chart

Division		Progress Time	Cotton		Sythetic		Eco	
			Small	Low	Small	Low	Small	Low
PRE WASH	Sensing	20sec.						
	Water Supply	2min.						
	Pre Wash	10min.						
		8min.						
	Drain	1min.						
	B-Spin	1min.						
Middle Spin	3min.							
MAIN WASH	Sensing	20sec.	■	■	■	■	■	■
	Water Supply	2min.	■	■	■	■	■	■
	Wash 1 (Heating)	90min.						
		35min.						
		30min.						
		20min.						
		15min.	■	■	■	■	■	■
	Wash 2	113min.						
		83min.			■ 23min.	■ 23min.	■ 23min.	■ 23min.
		23min.	■	■	■ 13min.	■ 13min..	■ 13min..	■ 13min.
RINSE	Drain	1min.	■	■	■	■	■	■
	B-Spin	1min.	■	■	■	■	■	■
	Middle Spin	4min.			■	■	■	■
	Water Supply	2min.	■	■	■	■	■	■
	Rinse 1-1	3min.	■	■	■	■	■	■
	Drain	1min.	■	■				
	B-Spin	1min.	■	■				
	Middle Spin	4min.						
	Water Supply	2min.	■	■				
	Rinse 1-2	3min.	■	■				
	Drain	1min.	■	■	■	■	■	■
	B-Spin	1min.	■	■	■	■	■	■
	Middle Spin	4min.	■	■	■	■	■	■
	Water Supply	2min.	■	■	■	■	■	■
	Rinse 2	3min.	■	■	■	■	■	■
	Drain	1min.	■	■	■	■	■	■
	B-Spin	1min.	■	■	■	■	■	■
	Middle Spin	4min.	■	■	■	■	■	■
	Water Supply	2min.	■	■	■	■	■	■
	Rinse 3	3min.	■	■	■	■	■	■
SPIN	Drain	1min.	■	■	■	■	■	■
	B-Spin	1min.	■	■	■	■	■	■
	Main Spin	14min.						
		7min.	■	■	■	■	■	■
		5min.	■	■	■	■	■	■
3min.	■	■	■	■	■	■		
END	Untangle	2min.	■	■	■	■	■	■
	End	10sec.	■	■	■	■	■	■
Remained Time Display			1:25	1:30	1:25	1:30	1:40	1:45

- NOTE**
- The washing time may vary by the amount of laundry, water pressure, water temperature and other washing conditions. If an unbalanced load is detected or if suds removing program operates, the washing time maybe extended. (Maximum increasing time is about 1hour.)
 - Spin speed 825 rpm is selected automatically with Cotton, Synthetic and Eco courses.

Division	Progress Time	Wool	Delicate 1X~5X	Sports wear 6X,7X	Hand wash	Quick 30	Rinse + Spin	
		Small	Small	Small	Small	Small	Low	
M A I N W A S H	Soak	30min.						
	Water Supply	2min.	■	■	■	■ (1min.)		
	Wash 1 (Heating)	60min.						
		50min.						
		35min.						
		30min.						
		5min.					■	
	Wash 2	20min.	■	■	(13min.)	■		
		10min.	■	■	■	■		
		5min.	■	■	■	■	■	
R I N S E	Drain	1min.	■	■	■	■		
	B-Spin	1min.	■	■	■			
	Middle Spin	4min.	■	■	■			
	Water Supply	2min.	■	■	■	■ (1min.)	■	
	Rinse 1	3min.	■	■	■	■	■	
	Drain	1min.	■	■	■	■		
	B-Spin	1min.	■	■	■			
	Middle Spin	4min.	■	■	■			
	Water Supply	2min.	■	■	■	■ (1min.)		
	Rinse 2	3min.	■	■	■	■		
	Drain	1min.				■		
	B-Spin	1min.				■		
	Middle Spin	4min.				■		
	Water Supply	2min.				■		
	Rinse 3	3min.				■		
S P I N	Drain	1min.	■	■	■	■	■	
	B-Spin	1min.	■	■	■	■	■	
	Main Spin	7min.	■	■	■	■	■	
		5min.	■	■	■	■	■	
E N D	Untangle	2min.	■	■	■	■	■	
	End	10sec.	■	■	■	■	■	
Remained Time Display		56	56	49	57	33	17	

NOTE

- The washing time may vary by the amount of laundry, water pressure, water temperature and other washing conditions. If an unbalanced load is detected or if suds removing program operates, the washing time maybe extended. (Maximum increasing time is about 1hour.)
- After the rinse progress in Quick30 course, the washer operating drain progress only without middle spin progress.
- Spin speed 400 rpm is selected automatically with Wool, Delicate(Sports Wear) and Hand Wash courses.
- Apply 'Delicate' course : DWD-FC1X1X ~ DWD-FC1X5X models.
Apply 'Sports Wear' course : DWD-FC1X6X, DWD-FC1X7X models.

Sequence Chart (for apply 'Islamic Rinse' option)

Example) Apply 'Islamic Rinse' option with Cotton/Normal course.

Division		Progress Time	Cotton/Normal		Islamic Rinse Option					
			S (A)	L (B)	S (a)	L (b)				
MAIN WASH	Sensing	20sec.	■	■	Same as 'A'	Same as 'B'				
	Water Supply	2min.	■	■						
	Wash 1 (Heating)	30min.	15min.				■			
			10min.	■			■			
			63min.							
	Wash 2	23min.	13min.	■			■			
RINSE	Drain	1min.	■	■	Same as 'A'	Same as 'B'				
	B-Spin	1min.	■	■						
	Middle Spin	4min.	■	■						
	Water Supply	2min.	■	■						
	Rinse 1	3min.	■	■						
	Drain	1min.		■	■	Same as 'A'	Same as 'B'			
			B-Spin	1min.	■			■		
			Middle Spin	4min.	■			■		
			Water Supply	2min.	■			■		
			Rinse 2	3min.	■			■		
	Drain	1min.		■	■	Same as 'A'	Same as 'B'			
			B-Spin	1min.	■			■		
			Middle Spin	4min.	■			■		
			Water Supply	2min.	■			■		
			Rinse 3	3min.	■			■		
Islamic Rinse 1	Drain	1min.			■	■				
	Water Supply	2min.			■	■				
	Rinse (with Water Supply and Drain)	3min.			■	■				
	B-Spin	1min.			■	■				
	Middle Spin	4min.			■	■				
Islamic Rinse 2	Water Supply	2min.			■	■				
	Rinse (with Water Supply and Drain)	3min.			■	■				
SPIN	Drain	1min.	■	■	Same as 'A'	Same as 'B'				
	B-Spin	1min.	■	■						
	Main Spin	7min.	5min.	■			■			
			3min.	■			■			
END	Untangle	2min.	■	■						
	End	10sec.	■	■						
Remained Time Display			1:25	1:30	1:41	1:46				

NOTE

- Islamic Rinse is available in Cotton, Synthetic, Hand Wash and Sports Wear programs.
- By selecting Islamic Rinse function, the washer operates two additional rinse times (Islamic Rinse process 1 and 2) after the basic rinse process. And then the washing time will be extended about 16 minutes.

8. FUNCTION OF THE CONVENIENT SERVICE

■ The test mode of the operation

You can check the PCB AS and the operation of the washing machine simply.

• The method to test and operate

- ① Press the Power button.
- ② Press the Option button 3 times while press the Temp button.
At this time, the version is displayed on the Custom LED
- ③ Whenever the Time Delay button is pressed, the washing machine is operated as following.
L_C (Lock Switch Close) → run/OO (The number of running times)
→ E5/OO → E6/OO → E7/OO → E8/OO (The number of the error occurrence)
→ H (Hot Valve) → C (Cold Valve) → P (Pre-Wash Valve)
→ bb (Bubble) → dr (Drain Pump)
→ C:H or C:-- (Cold & Hot Option)
→ nPC or PC or etc. (PCB Option) → L_O (Lock Switch Open)
→ L_C → ... (repetition)

■ The check mode of the water level frequency

You can check the water level frequency of the current state and the frequency by the variation of the water level.

• The method to test and operate

- ① Press the Power button.
- ② Press the Time Delay button 3 times while press the Temp button and the Spin button.
- ③ The water level frequency of the current state displays on "18:88 LED".

ex) **5 6 2** = 25.62kHz

: It display three number except the first number of 25.62kHz

- ④ Whenever the Temp button is pressed, the washing machine is operated as following.
Cold Valve Off (Initial state)
→ Cold Valve On
→ Hot Valve On
→ Pre-Wash Valve On
→ Bubble Pump On
→ Drain Pump On
→ ... (repetition)

■ The spinning test mode

You can continually spin the washing machine with constant speed.

• The method to test and operate

- ① Press the Power button.
- ② Press the Time Save button 3 times while press Temp button.
- ③ '400' displays on '18:88 LED'. 400 means the spinning rpm.
You can adjust the spinning rpm by pressing Spin button.
And this value increases by 50 up to 1400.
- ④ When press Start button, the washing machine continually operates with given spinning rpm.

■ The durability test mode

You can repetitively operate the washing machine with one course.

• The method to test and operate

- ① Press the Power button.
- ② Press the Time Delay button 3 times while press Temp button.
- ③ 'd3' displays on '18:88 LED'. You can select the course by using Program Dial, Temp button, Spin button, Option and Time Save button.
- ④ When press Start button, the washing machine repetitively operates with selected course.

9. TROUBLESHOOTING GUIDE

This washing machine is equipped with automatic safety function which detect and diagnose faults at an early stage and react appropriately.

When the machine does not function properly or does not function at all, check the following points.

SYMPTOM	CAUSE	SOLUTION
Rattling and clanking noise.	Foreign objects such as coins or safety pins maybe in the drum or pump.	Stop washer and check drum and filter.
Thumping sound.	Heavy wash loads may produce a thumping sound. This is usually normal.	If sound continues, washer is probably out of balance. Stop and redistribute wash load.
Vibrating noise.	Have all the transit bolts and packing been removed?	If not removed during installation, refer to installation guide for removing transit bolts.
	Are all the feet resting firmly on the ground?	Wash load may be unevenly distributed in drum. Stop washer and rearrange wash load.
Water leaks.	Inlet hoses or drain hose are loose at tap or washer.	Check and tighten hose connections.
	House drain pipes are clogged.	Unclog drain pipe. Contact plumber if necessary.
Oversudsing.		Too much detergent or unsuitable detergent may cause excessive foaming which may result in water leaks.
Water does not enter washer or it enters slowly.	Water supply is not adequate in area.	Check another tap in the inlet house.
	Water supply tap is not completely open.	Fully open tap.
	Water inlet hose is kinked.	Straighten hose.
	The filter of the water inlet is clogged.	Check the filter of the water inlet.
Water in the washer does not drain or drains slowly.	Drain hose is kinked or clogged.	Clean and straighten drain hose.
	The drain filter is clogged.	Clean the drain filter.

SYMPTOM	CAUSE	SOLUTION
Washer does not start.	Electronical power cord may not be plugged in or connection may be loose.	Make sure plug fits tightly in wall outlet.
	House fuse blown, circuit breaker tripped, or a power outage has occurred.	Reset circuit breaker or replace fuse. Do not increase fuse capacity. If problem is a circuit overload, have it corrected by a qualified electrician.
	Water supply tap is not turned on.	Turn on water supply tap.
Washer will not spin.	Check that the door is firmly shut.	Close the door and press the Start/Pause button. After pressing the Start/Pause button, it may take a few moments before the clothes washer begins to spin. The door must lock before spin can be achieved.
Door does not open.		Once started, the door can not be opened for safety reasons. Wait two minutes before opening the door to give the electric locking mechanism time to release.
Wash cycle time delayed.		The washing time may vary by the amount of laundry, water pressure, water temperature and other usage conditions. If the imbalance is detected, the wash time shall be increased.
The washer will stop during spinning . Spinning is insufficient.	PFE error due to much detergent and unsuitable detergent.	If PFE error mode was displayed on the control part, in order to solve this problem, first turn off the power of the washing machine, second turn on the power pressing Power button, third press SPIN button and last press Start/Pause button.

MESSAGE	ERROR	CAUSE	SOLUTION
IE	WATER INLET ERROR	The water tap is closed.	Open the water tap.
		The filter of the valve inlet is clogged.	Clean the filter of the valve inlet.
		The valve inlet is an inferior product or broke down.	Change the valve inlet.
		The water level sensor (sensor pressure) is an inferior product or broke down.	Change the water level sensor (sensor pressure).
		The drain motor works during water supply.	Change the drain motor.
		The PCB ASS'Y does not check the water level.	Change the PCB ASS'Y.
OE	DRAIN ERROR	The drain hose is kinked or clogged.	Clean and straighten the drain hose.
		The drain motor is an inferior product.	Change the drain motor.
		The valve inlet works during drain.	Change the valve inlet.
		The water level sensor is an inferior product.	Change the water level sensor.
		The PCB ASS'Y does not check the water level.	Change the PCB ASS'Y.
UE	UNBALANCE ERROR	The laundry is concentrated to one side of the drum during spin.	Rearrange the laundry.
LE	DOOR OPEN ERROR	The Start/Pause button is pressed while the door is opened.	Close the door.
		The switch door lock is an inferior product.	Change the switch door lock.
		The PCB ASS'Y does not check the door lock.	Change the PCB ASS'Y.
E2	OVERFLOW ERROR	The water is supplied continuously due to an inferior valve inlet.	Change the valve inlet.
		The valve inlet is normal, but the water level sensor (sensor pressure) is inferior.	Change the water level sensor (sensor pressure).
		The drain motor does not work. (The drain motor is an inferior product or broke down.)	Change the drain motor.
E4	LEAKAGE ERROR	Water leaks from the tub or the hose drain.	Check the leak of the tub or the hose drain. Then change the tub or the hose drain.
E5	HIGH VOLTAGE ERROR	The laundry is jammed between the gasket and the drum.	Rearrange the laundry.
		The PCB ASS'Y is an inferior product.	Change the PCB ASS'Y.
E6	EMG ERROR	The laundry is jammed between the gasket and the drum.	Rearrange the laundry.
		The motor is an inferior product.	Change the motor.
		The PCB ASS'Y is an inferior product.	Change the PCB ASS'Y.
E8	MOTOR ERROR	The motor is not normally connected.	Check the connector of the motor.
		The motor does not work. (The motor is an inferior product or broke down.)	Change the motor.
E9	SENSOR PRESSURE ERROR	The water level sensor is an inferior product.	Change the water level sensor.
H2	THERMISTOR WASH ERROR	The thermistor wash is an inferior product or broke down.	Change the thermistor wash.
		The thermistor wash is not connected normally.	Check the connector of the thermistor wash.
H4	THERMISTOR WASH OVERHEATING ERROR	The heater worked without the water in the tub.	Check the water level.
		The thermistor wash is an inferior product or broke down.	Change the thermistor wash.

MESSAGE	ERROR	CAUSE	SOLUTION
H5	WATER TEMP. ERROR	The water temp. is over 45°C in delicate & wool course. (The thermistor wash is an inferior product or broke down.)	Change the thermistor wash.
H6	HEATER WASH ERROR	The heater wash dose not work. (The water temp. doesn't rise over 2°C during 15min.)	Change the heater wash.
H8	HEATER WASH OVERHEATING ERROR	The heater worked without the water in the tub.	Check the water level and the heater wash.
lb	IGBT ERROR	The PCB ASS'Y is an inferior product.	Change the PCB ASS'Y.
PFE	PUMP FILTER ERROR	The drain pump filter is clogged.	Clean the drain pump filter.
		The drain pump does not work during spin.	Change the drain pump.
		The large amount of detergent was used.	Use the proper amount of detergent.
		The drain hose is placed higher than 1m above the floor.	Place the drain hose 1m below the floor.

10. WIRING DIAGRAM

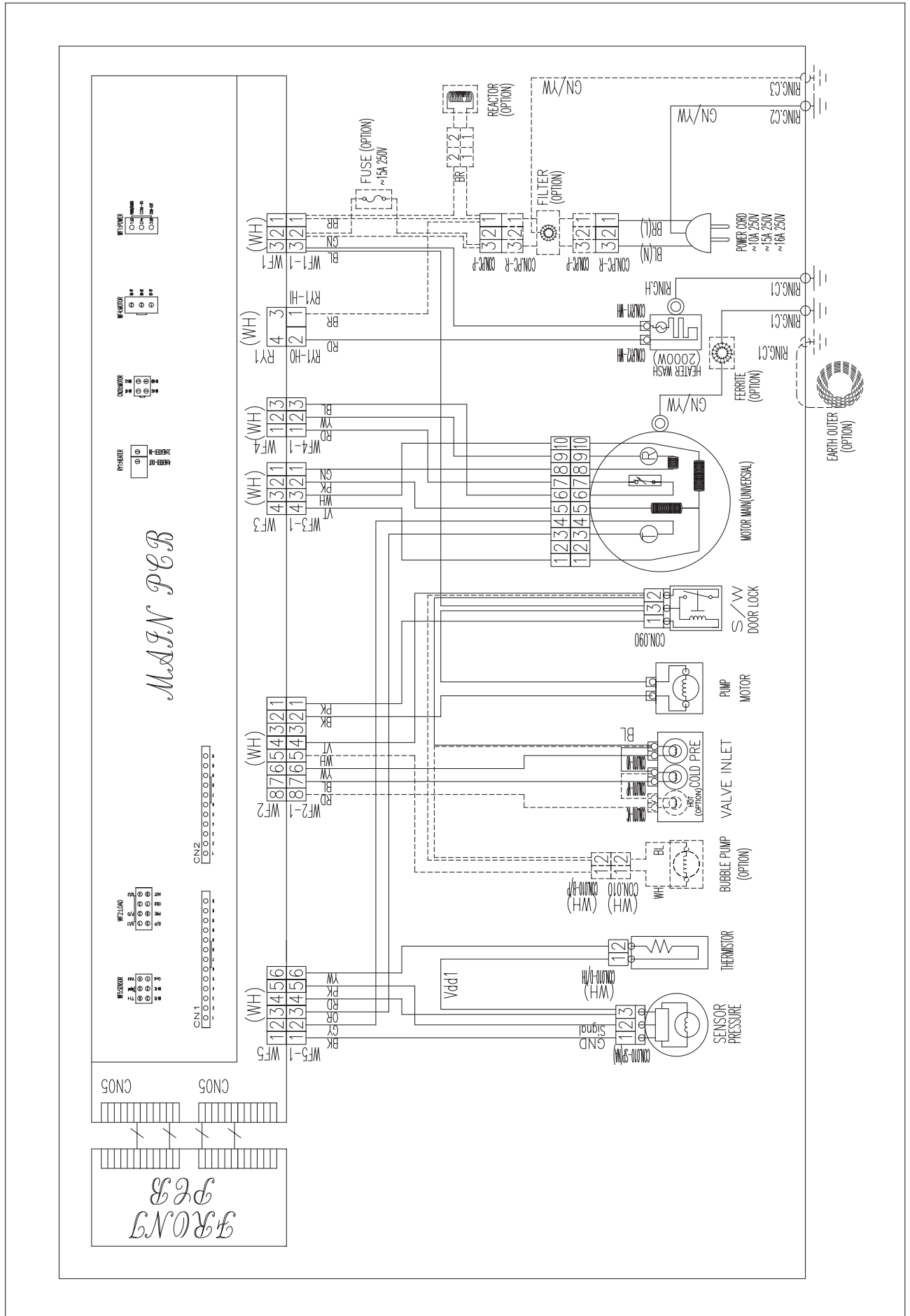



DAEWOO ELECTRONICS CORP.

1-2, Jeo-dong 1(il)-ga, Jung-gu, Seoul, Korea

C.P.O. BOX 8003 SEOUL, KOREA

TELEX: DWELEC K28177-8

CABLE: □AEWOOELEC"

PRINTED DATE: Aug. 2013

S/M NO. :

ABOUT THIS MANUAL

VISION CREATIVE, INC.

서울 종로구 통의동
6번지 이룸빌딩 4층

담 당	김혜웅 님
MODEL	DWD-FC1011/FC1012/FC1013/FC1211/FC1212/FC1213
	DWD-FC1021/FC1022/FC1023/FC1221/FC1222/FC1223
	DWD-FC1031/FC1032/FC1033/FC1231/FC1232/FC1233
	DWD-FC1041/FC1042/FC1043/FC1241/FC1242/FC1243
	DWD-FC1051/FC1052/FC1053/FC1251/FC1252/FC1253
	DWD-FC1061/FC1062/FC1063/FC1261/FC1262/FC1263
	DWD-FC1071/FC1072/FC1073/FC1271/FC1272/FC1273
	DWD-FC1081/FC1082/FC1083/FC1281/FC1282/FC1283
접 수	2013.08.06 (S/M)
MEMO 총 68p 13.08.06-전체 신규 68p 13.08.07-21p 수정_신규 1p	

연락처

VISION 담당 방문수

TEL: 730-0660 FAX: 730-3788