

S/M No.: FRPE400002

Service Manual

TMF 34 / 36 series..) Refrigerator



FR-37.. / FR-39..

✓ **Caution**

In this manual, some parts can be changed for improving their performance without notice. So, If you need the latest parts information, please visit and refer to PPL (Parts Price List) in Service Information Center. (<http://svc.dwe.co.kr>)

Mar. 2014.

WARNINGS AND PRECAUTIONS FOR SAFETY

Please observe the following safety precautions in order to use safely and correctly the refrigerator and to prevent accident and danger during repair.

1. Be care of an electric shock. Disconnect power cord from wall outlet and wait for more than three minutes before replacing PCB parts.
Shut off the power whenever replacing and repairing electric components.
2. When connecting power cord, please wait for more than five minutes after power cord was disconnected from the wall outlet.
3. Please check if the power plug is pressed down by the refrigerator against the wall.
If the power plug was damaged, it may cause fire or electric shock.
4. If the wall outlet is over loaded, it may cause fire.
Please use its own individual electrical outlet for the refrigerator.
5. Please make sure the outlet is properly earthed, particularly in wet or damp area.
6. Use standard electrical components when replacing them.
7. Make sure the hook is correctly engaged.
Remove dust and foreign materials from the housing and connecting parts.
8. Do not fray, damage, machine, heavily bend, pull out or twist the power cord.
9. Please check the evidence of moisture intrusion in the electrical components.
Replace the parts or mask it with insulation tapes if moisture intrusion was confirmed.
10. Do not let the customers repair, disassemble and reconstruct the refrigerator for themselves.
It may cause accident, electric shock, or fire.
11. Do not store flammable materials such as ether, benzene, alcohol, chemicals, gas, or medicine in the refrigerator.
12. Do not put flower vase, cup, cosmetics, chemicals, etc., or container with full of water on the top of the refrigerator.
13. Do not put glass bottles with full of water into the freezer.
The contents shall freeze and break the glass bottles.
14. When you scrap the refrigerator, please disconnect the door gasket first and scrap it where children are not accessible.

1. Specification

Factory No.		FRE-34..	FRE-36..
Buyer No.		FR-37..	FR-39..
Storage Volume. (ISO62552)	Total	345L	362L
	Freezer	99L	99L
	Refrigerator	246L	263L
Net Dimension (with handle)	Width	668mm	668mm
	Depth (With handle)	680mm	680mm
	Height	1644mm	1704mm
Cooling Cycle	Refrigerant type	R-134a	
	Refrigerant charge	85g	
	Evaporator type	Fin Type	
	Colling system	Fan cooling system	
Heater	Defrost heater	150W	
	Defrost control	Automatic start & stop	
Electronic Part	Fuse temp.	77℃	
	Refrigerator lamp	0.6W x 1ea (LED)	
	Fan motor	AC Motor	
Net Weight		62kg	65kg

2. External Size

[FR-37...]

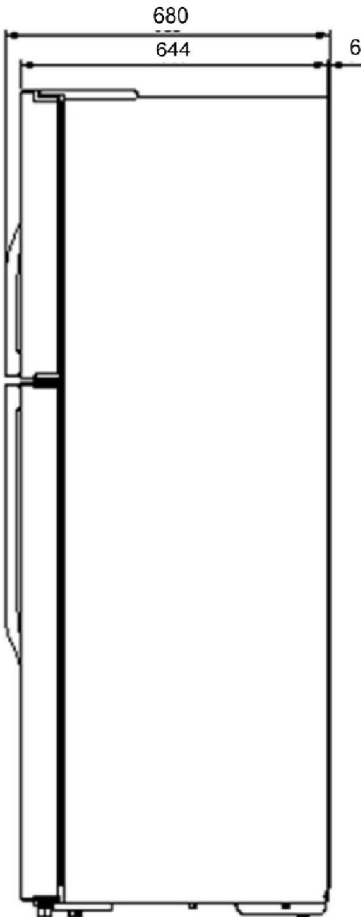
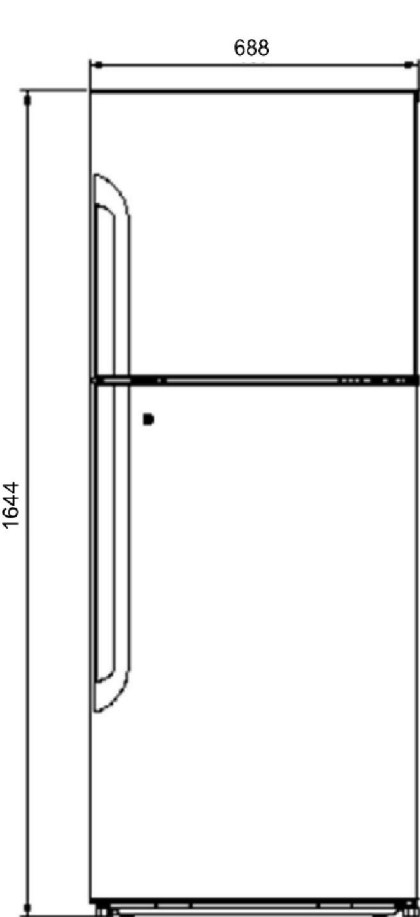
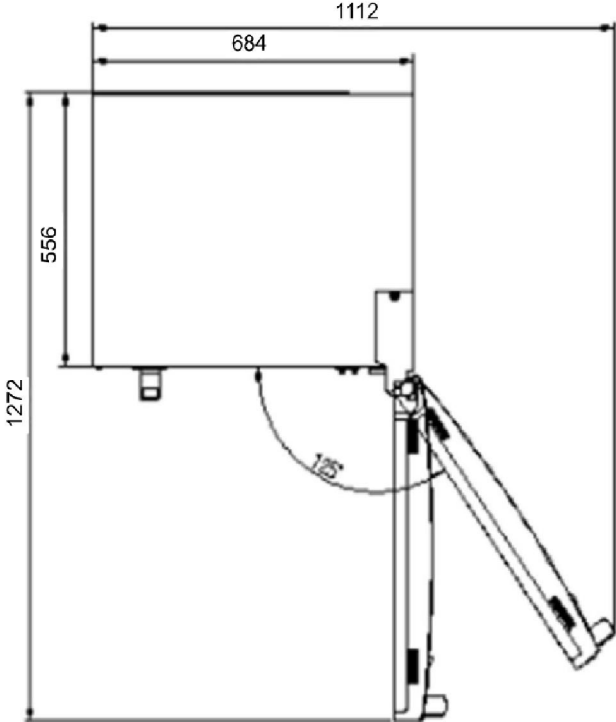

[FR-39..]

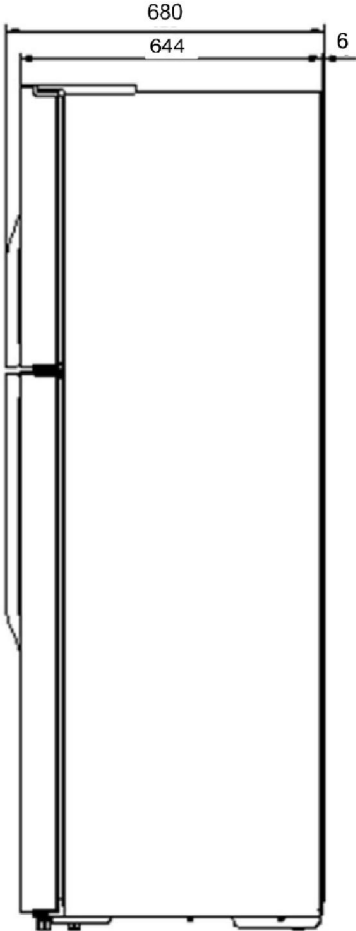
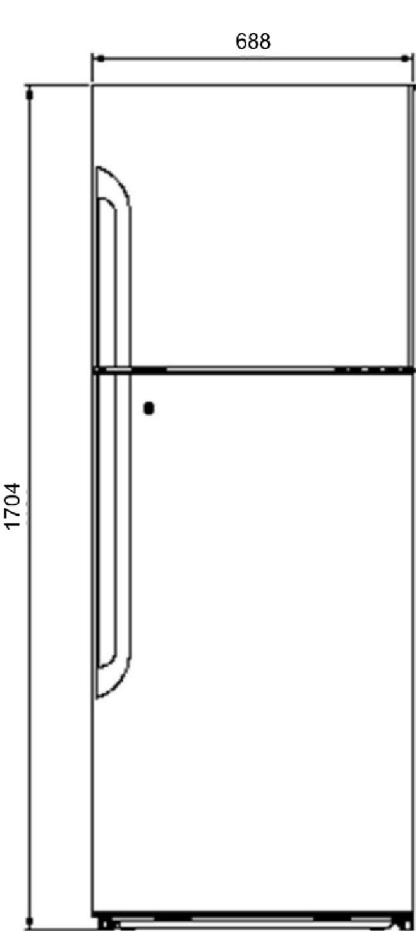
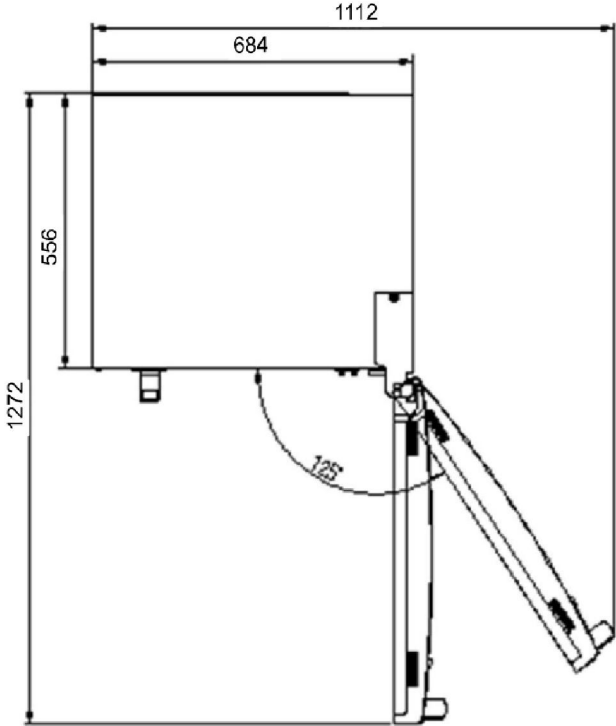

3. Interior Parts

[All Model..]

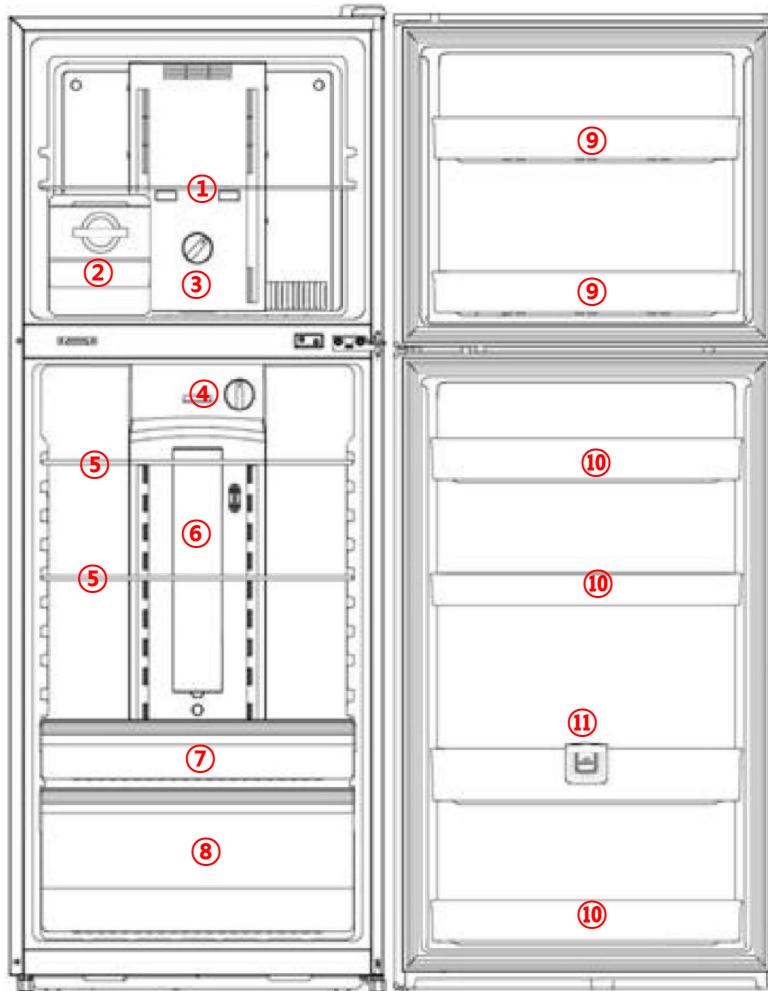

1) Freezer Compartment Shelf

2) Twist Ice maker +Cool pack **[Option]**

3) Freezer Temperature Controller

4) Refrigerator Temperature Controller

5) Refrigerator Compartment Shelf

6) Refrigerator Compartment Lamp

7) Fresh Case **[Option]**

8) Vegetable Case

9) Freezer Compartment Pockets

10) Refrigerator Compartment Pockets

11) Pocket Guide (Anti Bacteria Filter)
[Option]

1. Temperature control

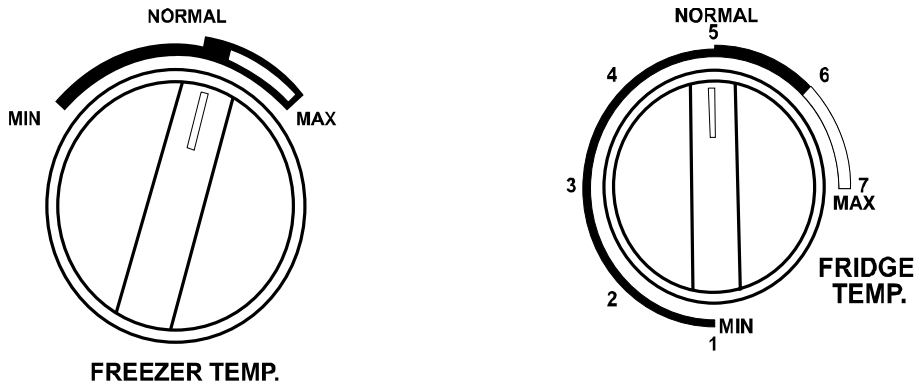

1) Freezer temperature control.

- Temperature controlled by rotating volume dial.
- No relation with Sensor or M-PCB. It just controls the cold air hole. (Max is fully open)

2) Refrigerator temperature control.

- Temperature controlled by rotating volume dial.
- Inner real temperature controlled by sensor on/off point. (*refer to below chart)

Normal condition) $18^{\circ}\text{C} < \text{RT-Sensor} \leq 28^{\circ}\text{C}$

STEP	1(MIN)	2	3	4	5(NORMAL)	6	7(MAX)
On	8.3°C	6.0°C	5.2°C	4.1°C	3.0°C	1.9°C	0.9°C
Off	4.9°C	2.7°C	1.9°C	0.9°C	-0.2°C	-1.3°C	-2.3°C

Normal condition) $28^{\circ}\text{C} < \text{RT-Sensor} \leq 39^{\circ}\text{C}$

STEP	1(MIN)	2	3	4	5(NORMAL)	6	7(MAX)
On	8.3°C	6.0°C	5.2°C	4.1°C	3.0°C	1.9°C	0.9°C
Off	4.9°C	2.7°C	1.9°C	0.9°C	-0.2°C	-1.3°C	-2.3°C

Unnormal condition) $\text{RT-Sensor} \leq 12^{\circ}\text{C}$ _ (Weak cooling _ Winter season)

STEP	1(MIN)	2	3	4	5(NORMAL)	6	7(MAX)
ON	4.9°C	2.7°C	1.9°C	0.9°C	-0.2°C	-1.3°C	-2.3°C
OFF	3.8°C	1.6°C	0.9°C	-0.2°C	-1.3°C	-2.3°C	-3.4°C

Unnormal condition) $12^{\circ}\text{C} < \text{RT-Sensor} \leq 18^{\circ}\text{C}$ _ (Weak cooling _ Winter season)

STEP	1(MIN)	2	3	4	5(NORMAL)	6	7(MAX)
ON	6.7°C	4.5°C	3.8°C	2.7°C	2.3°C	0.5°C	-0.6°C
OFF	5.2°C	3.0°C	2.3°C	1.2°C	0.9°C	-0.9°C	-2.0°C

Unnormal condition) $\text{RT-Sensor} > 37^{\circ}\text{C}$

STEP	1(MIN)	2	3	4	5(NORMAL)	6	7(MAX)
ON	8.3°C	6.0°C	5.2°C	4.1°C	3.0°C	1.9°C	0.9°C
OFF	4.9°C	2.7°C	1.9°C	0.9°C	-0.2°C	-1.3°C	-2.3°C

2. Defrosting Mode

1.) Determination of defrosting mode.

-When total operation of compressor becomes 6, 8, 10, 12 hours.

- ▶ any error mode (such as R1, RT, D1, F3) happens.
- ▶ running rate of Comp (per 2hrs of total operation time) is more than 90%.
- ▶ Door opening time is over 2 minutes.

-If the above conditions are not satisfied

- ▶ Defrost mode starts immediately when total operation time of Comp. is over 12hours.
- ▶ or defrost mode starts immediately as long as total time (Comp. on time + Comp. off time) is 72hours.

3. Defrosting Process

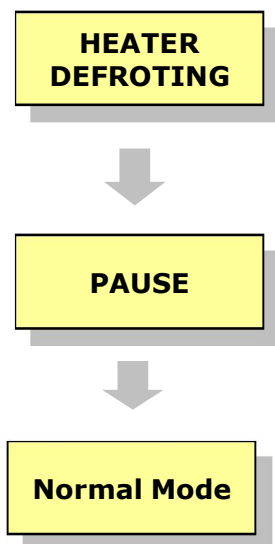

1) HEATER DEFROSTING

- Defrost heater is switch on until Defrost Sensor temperature reaches 10C.
- Heater operation time.
 - ; 30 minutes - When Defrost Sensor is malfunction. (D1 error)
 - ; 60 minutes - Heater maximum operation time. (F3 error)

2) PAUSE

- After Defrost Heater switch OFF, Heater and Comp. are all off for 15 minute.

Division	HEATER DEFROST	PAUSE
Compressor	OFF	OFF
Freezer Fan	OFF	OFF
Refrigerator Fan	OFF	OFF
Defrost Heater	ON	OFF
Time	60mn 80min (D1 error)	10min 15min(After comp's total operating hour is 6hours)

4. Foced Defrost Mode

- How to start : rotate refrigerator`s volume dial from 1 step to 5step while pushing the door switch.
- Process : Heater is on initial 30 seconds regardless the temperature of D-Sensor.
- How to exit: Waiting until general Defrost Mode off.

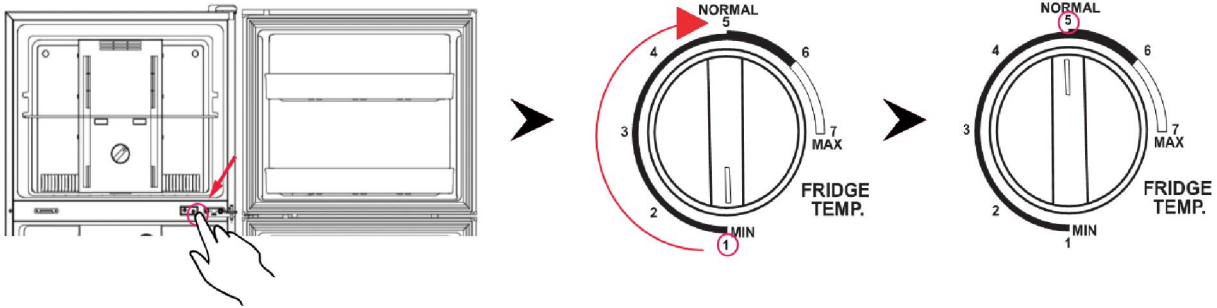

5. Initial Defrosting.

- If defrosting sensor temperature is below 3.5`c in initial power input. Normal defrosting mode starts.

6. Prevention of Compressor Restart.

- Compressor doesn't restart for about 6 minutes to protect compressor regardless of refrigerator sensor.

1. How to check the error mode.

- To confirm error happens or not. Check LED on Main PCB.
- If error happens , The Led is flickers according to Error types.
- ▶ After all errors return to normal condition . Flickers will turn off .

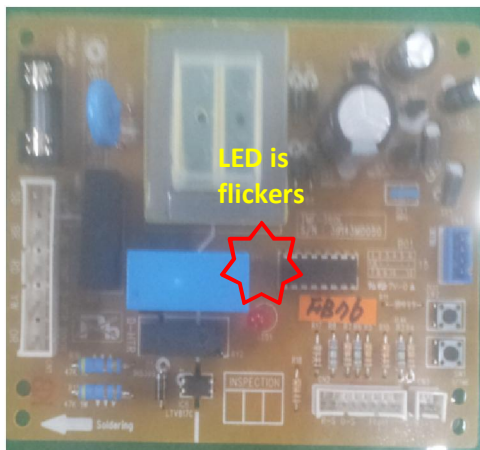

2. Error Code.

No	Flickers (LED)	Remark
1	On/Off : 1 time	Refrigerator Sensor is disconnection or short
2	On/Off : 2 times	RT-Sensor is disconnection or short
3	On/Off : 3 times	Defrost sensor is disconnection or short
4	On/Off : 4 times	Return after defrosting : abnormal or defective
5	On/Off : 5 times	Refrigerator Door switch is defective. Or Refrigerator Door is open For at leaste 1hour .

; All Error Code reset, when the relative parts turn into normal.

1. Circuit Diagram

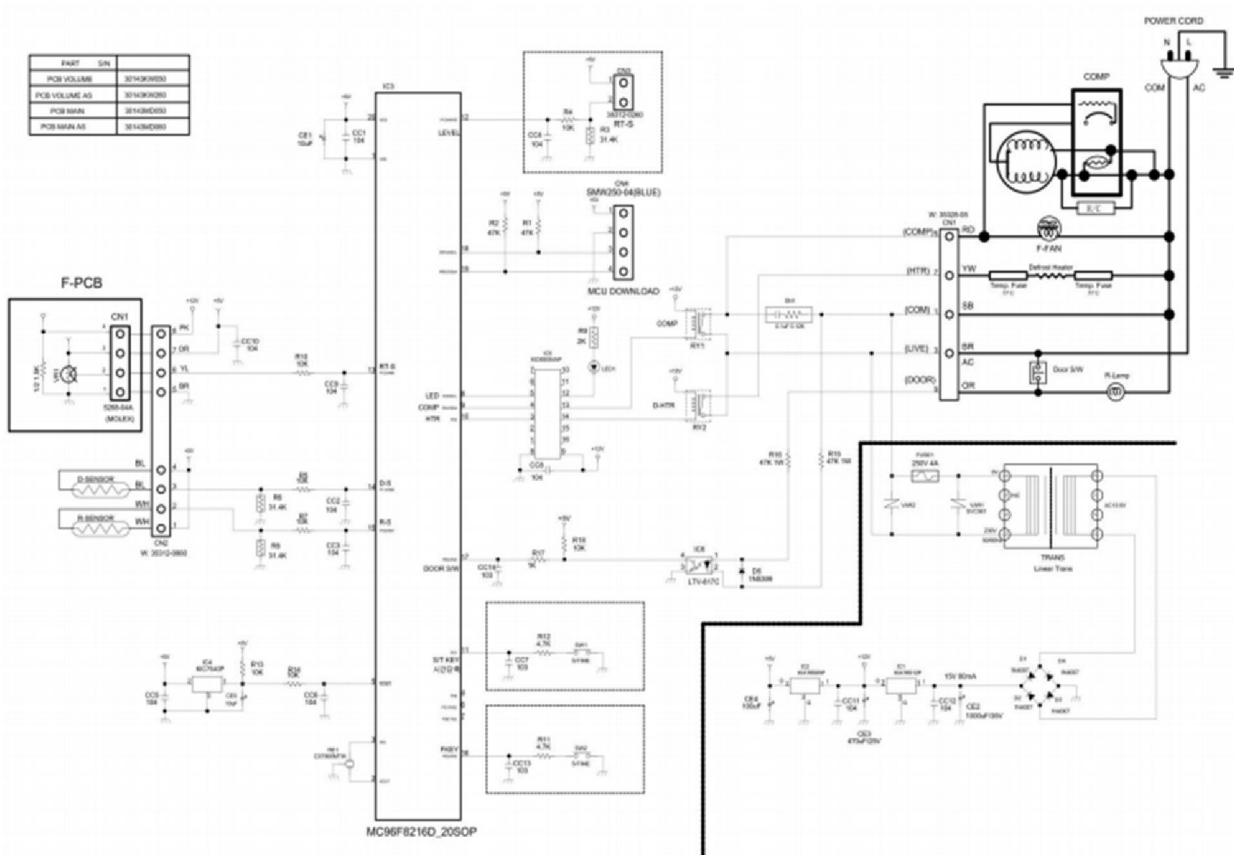

2. Wiring Diagram

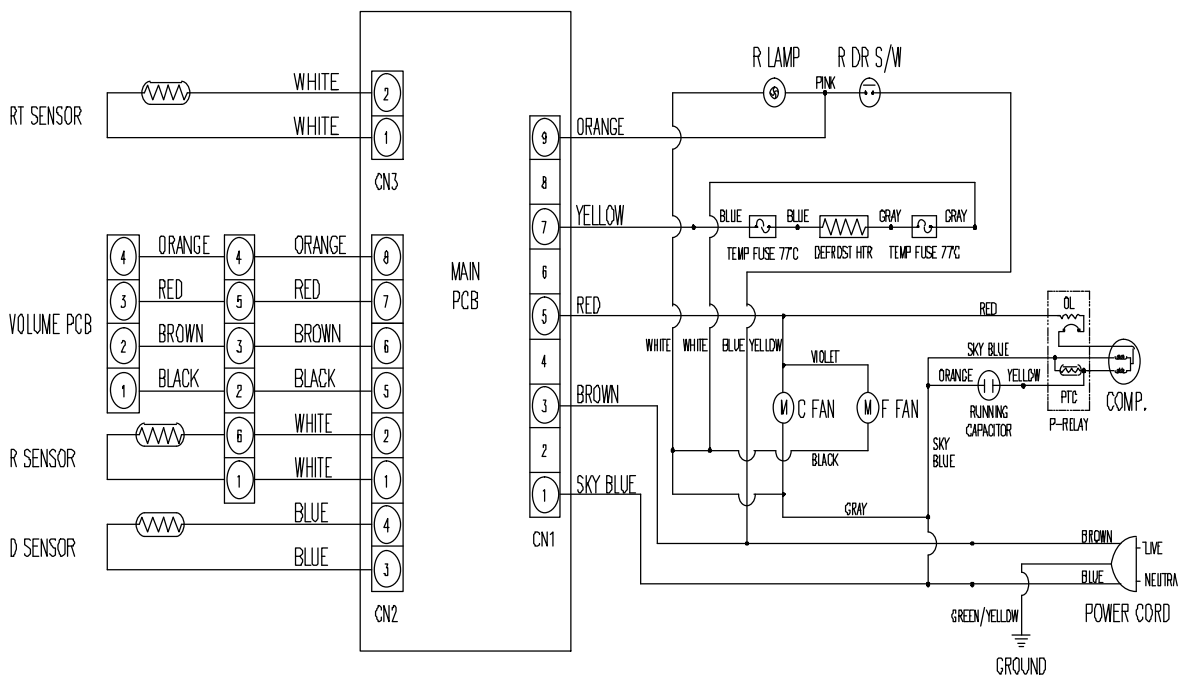

2. Refrigerant Cycle Diagram

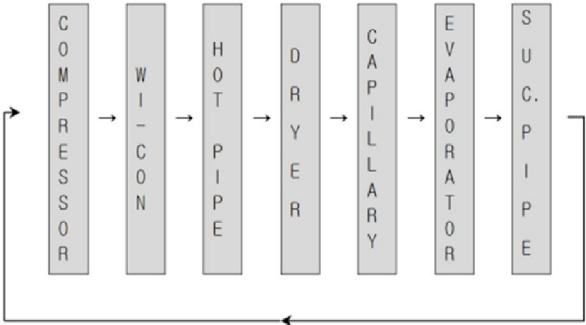
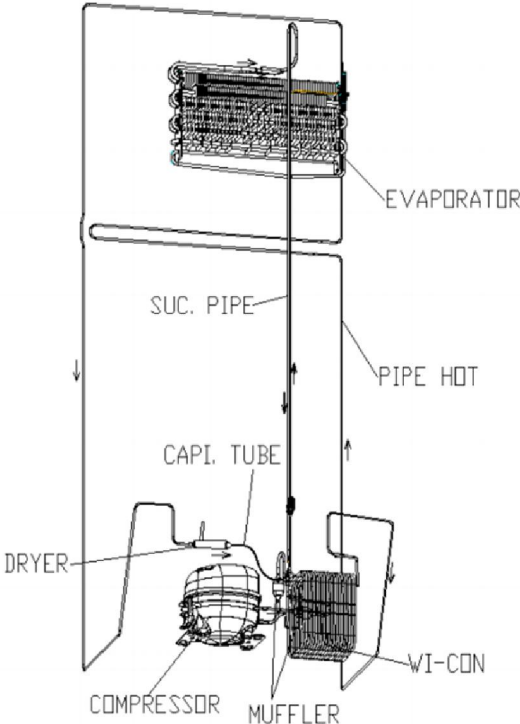

3. Air Flow Diagram

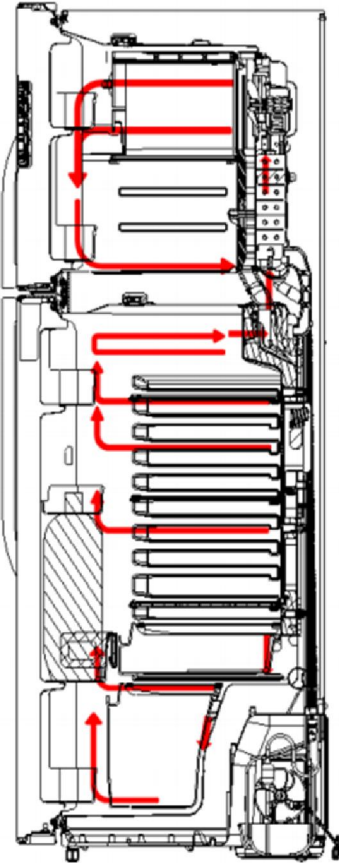

1. Freezer Louver



1) Remove screw cap on the Freezer Louver.



2) Remove 2 screws.



3) Pull forward the Freezer Louver.



4) Disconnect fan motor lead Wire.

2. M/Flow Duckt & Lamp (Refrigerator Compartment.)



1) Remove screw cap on the Freezer Louver.



2) Unlock the hook on the bottom of the Deco M/Flow duct then remove the Deco M/Flow duct.



3) Remove the LED Lamp . If necessary.



4) Remove 3 screws.



4) Pull forward the M/Flow duct.
Disconnect the lead wires and Sensor.

4. Main PCB



1) Remove the 2 screws.

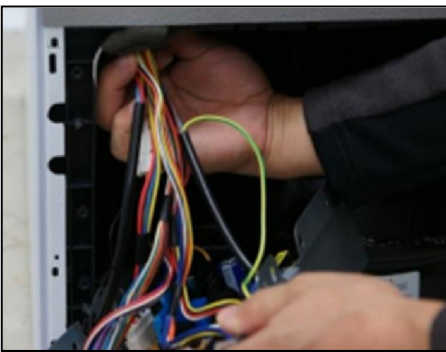

2) Disconnect the lead wires of Power Cord and Compressor relay.



3) Remove the Power Code and harness from the main pcb housing.

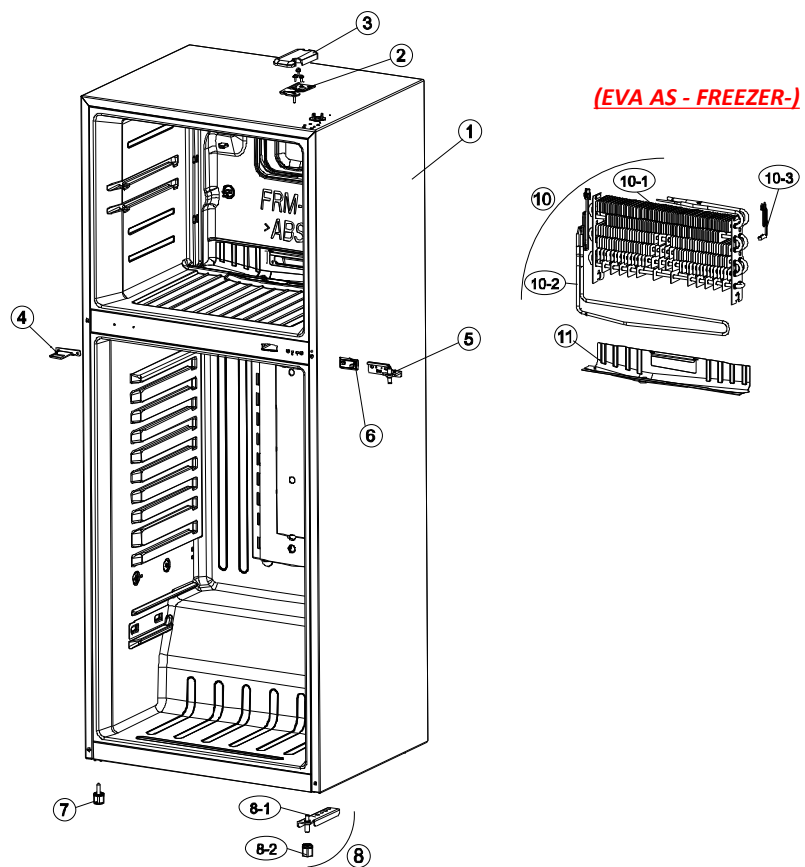

NO	PART-CODE	PART NAME	SPEC.	Q'ty
1	-	ASSY CAB URT	-	1
2	3012939200	HINGE *T AS	T2.6*W247*L65	
3	300149DS00	COVER *T HI	FRE-361,PP J370A	
4	3015300110	SUPPORTER LOCK	PO/T2.0. OPTION	
5	3012939400	HINGE *M AS	FRT-512N..	
6	3018100010	SWITCH DR	2 BUTTON/4P,DSD-5	
7	3012106500	FOOT ADJ *L AS	PP+INSERT	
8	3012939300	HINGE *U AS	-	
8-1	3012939600	HINGE *U	SPHC T3.0*W348*L67	
8-2	3012106600	FOOT ADJ AS	PP J370A + M10 NUT	
10	3017071400	EVA AS	220-240V	
10-1	3017071500	EVA SAS	FIN-TYPE	
10-2	3012832800	HEATER SHEATH AS	220V/150W	
10-3	3012767720	SENSOR D AS	ABS CAP	
11	3012554700	GUIDE DRN	FRE-361,GL T0.35	

- Some parts can be changed for improving their performance without notice.

Date	Amendment Note

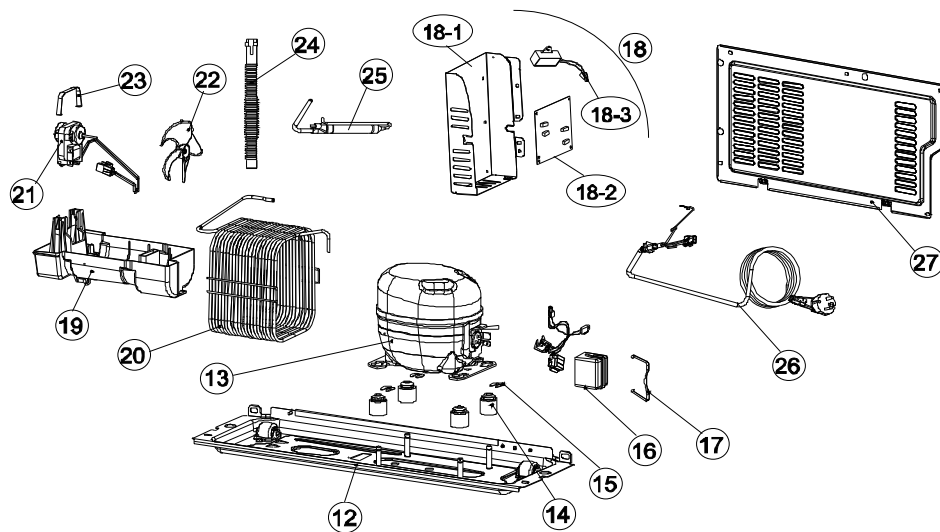

NO	PART-CODE	PART NAME	SPEC.	Q'ty
12	3010368900	BASE COMP AS	-	1
13	-	COMPRESSOR	Refer to Specification of electric parts	
14	3010101600	ABSORBER COMP	NBR	
15	4019H09031	SPECIAL WASHER	SWRH	3
16	-	COVER RELAY	Refer to Specification of electric parts	1
17	3012610000	CLAMP BAND RELAY	SK-5 0.7T	
18	-	BOX M/PCB AS	Refer to Specification of electric parts	
18-1	3010586800	BOX M/PCB	SGCC T0.4*W285*L270	
18-2	-	PCB MAIN AS	Refer to Specification of electric parts	
18-3	-	CAPACITOR RUN	Refer to Specification of electric parts	
19	3011117560	CASE VAPORI SAS	FRE-361, AL TAPE + PE SEAL	
20	3014434030	PIPE WICON AS	6.5 PITCH, FRE-361,L12697	
21	-	MOTOR C	Refer to Specification of electric parts	
22	3011801320	FA C AS	110(FAN)3.17(SHAFT), GLASS-FIBER	
23	3012006001	FIXTURE C MOTR AS	SUS304+NR	
24	3013201700	HOSE DRN B	PE	
25	3016808230	DRYER AS	SINGLE TUBE	
26	-	CORD POWER AS	Country dependent	
27	300149E200	COVER MACH RM	SGCC,T0.25*W590*L320	

SPECIFICATION OF ELECTRIC PARTS

VOLTAGE	220-240V/50Hz		220-240V/50Hz		220V/60Hz		110V/60Hz	
REFRIGERATOR	R-134a / 85g		R-600a		R-134a/85g		R-134a	
PART NAME	PART-CODE	SPEC.	PART-CODE	SPEC.	PART-CODE	SPEC.	PART-CODE	SPEC.
COMP	3956180055	220-240V/50HZ,RSCR			3956160040	220V/60Hz, RSCR		
SWITCH P RELAY AS	3018135410	OLP: 213NHBY-52, BT68-120A69D2. PTC: 33Ω			3018135400	OLP: 213NHBY-52, BT68-120A69D2. PTC: 22Ω		
COVER RELAY	3811400503	PP(SW5101SW)			3811400503	PP(SW5101SW)		
MOTOR C	3015909800	S6111CEC05,AC230V/50HZ			3015910010	S6111GEC06,AC220V/60HZ		
BOX M/PCB AS	3010587310	230V/50HZ,SEMI-ELEC			3010587300	220V/60HZ,SEMI-ELEC		
↳ CAPACITOR RUN	3016402060	400V,6 μF, WIRE, P2			3016405800	350V,4 μF, WIRE, P2		
↳ MAIN PCB AS	30143MD060	FR-1 122X97-1.6T,361			30143MD060	FR-1 122X97-1.6T,361		

▼ Freezer Compartment

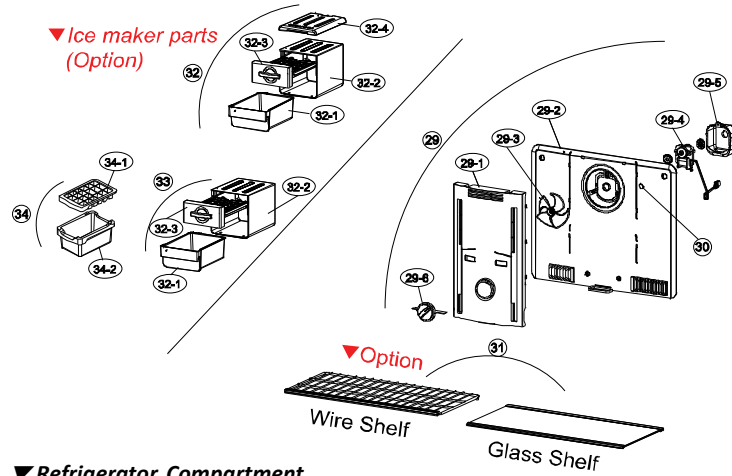

▼ Refrigerator Compartment

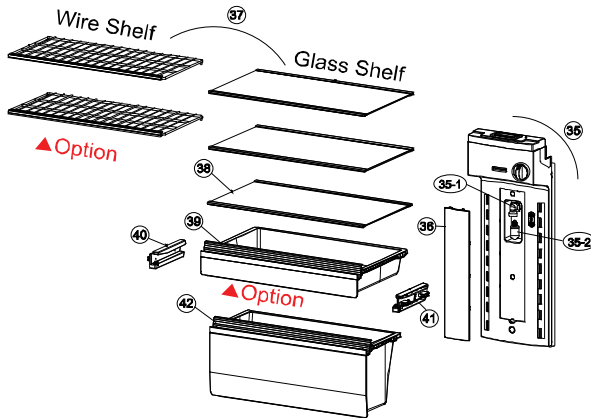

NO	PART-CODE	PART NAME	SPEC.	Q'ty	
29	3018934400	LOUVER F AS	FRE-361,220V/60HZ	1	
	3018934410		FRE-361,230V/50HZ		
29-1	300149DX00	COVER F FAN	PP I370A, FRE-361		
29-2	3018934000	LOUVER F	FRE-361,HIPS HI450		
29-3	3011802700	FAN AS	FAN(OD110)+CLAMP		
29-4	3015924500	MOTOR F AS	AC220V/60Hz , S6112GDF10		
	3015924600		AC230V/50Hz , S6111CDF05		
29-5	3012045400	FIXTURE MOTR *B	PP I370A		
29-6	3013416400	KNOB F CONTL	HIPS HI450		
30	3010924600	CAP F LOUVER	HIPS T2.3		2
31	3017867900	SHELF F GLAS AS	NON H/STAMP,GLASS		1
	3017867910	SHELF F GLAS AS	H/STAMP(DECO),GLASS , OPTION		
	3017867200	SHELF F WIRE AS	H/STAMP(DECO),WIRE SHELF , OPTION		
32	3010404510	BODY I/MAKER AS	FRAME I/ MACKER+CASE+COOL PACK, OPTION		
32-1	301119WS00	CASE ICE	MF21-301		
32-2	3010404400	BODY I/MAKER	-		
32-3	3012253700	FRAME I/MACKER AS	-		
32-4	301119WZ00	CASE I/PACK AS	-		
33	3010404500	BODY I/MAKER AS	FRAME I/ MACKER+CASE , OPTION		
34	301119V600	CASE ICE AS	CASE ICE+CASE ICING+VINYL		
34-1	4010G56012	CASE ICING	PP		
34-2	4017Z99112	CASE ICE	HC-2		
35	301149E900	COVER M/F DUCT AS	FRE-36. , 230V		
35-1	3017903910	SOCKET LAMP AS	AC250V,L300,PBT UL94V-0		
35-2	3017908200	SOCKET LED LAMP	230V 0.6W		
36	3011670200	DECO M/F DUCT	GPPS MF21-301		
37	3017868300	SHELF R GLAS AS	NON H/STAMP,GLASS	2	
	3017868310		H/STAMP(DECO),GLASS , OPTION		
	3017867000		H/STAMP(DECO),WIRE SHELF , OPTION		
38	3017867500	SHELF C/C GLAS AS	NON H/STAMP		
	3017867510		H/STAMP(DECO), OPTION		
39	301119Y300	CASE CHILD AS	NON H/STAMP+VINYL OPTION		
	301119Y310		H/STAMP(DECO)+VINYL OPTION		
40	3012555500	GUIDE C/C *L AS	PP, ROLLER		
41	3012555700	GUIDE C/C *R AS	PP, ROLLER		
42	301119Y500	CASE VEGETB AS	NON H/STAMP+VINYL		
	301119Y510		H/STAMP(DECO)+VINYL OPTION		

- Some parts can be chaged for improving their performance without notice.

Date	A mendment Note

▼ Freezer Door

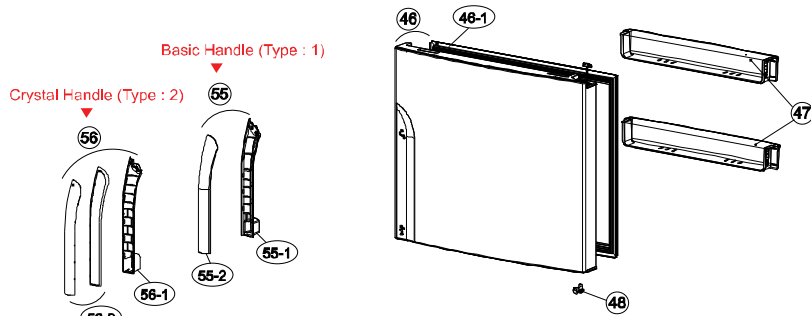

▼ Refrigerator Door

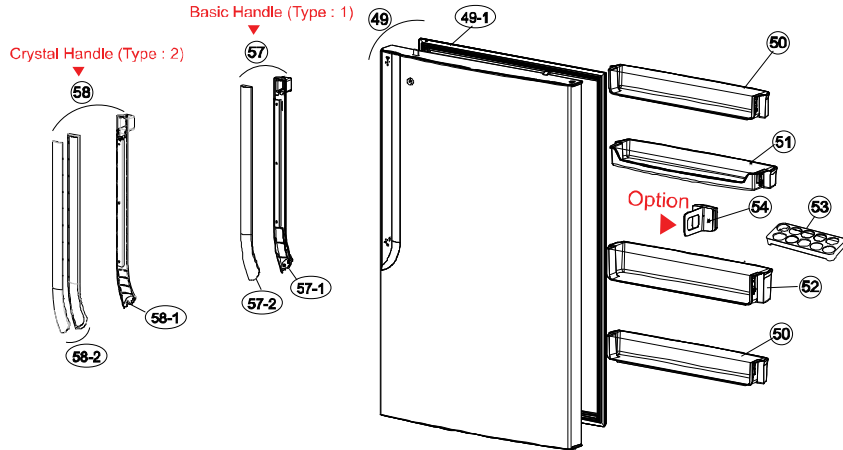

NO	PART-CODE	PART NAME	SPEC.	Q'ty			
				FR-371..	FR-372..	FR-391..	FR-392..
46	30100C8Y00	ASSY F DR	WHITE PCM,BASIC HANDLE_NON SPRAY	1	X	X	X
	30100C8Y10		METALON SILVER,BASIC HANDLE_SPRAY	1	X	X	X
	30100C8YA0		WHITE PCM,CRYSTAL HANDLE	X	1	X	X
	30100C8YB0		METALON SILVER,CRYSTAL HANDLE	X	1	X	X
	30100C8Q00		WHITE PCM,BASIC HANDLE_NON SPRAY	X	X	1	X
	30100C8Q10		METALON SILVER,BASIC HANDLE_SPRAY	X	X	1	X
	30100C8QA0		WHITE PCM,CRYSTAL HANDLE	X	X	X	1
	30100C8QB0		METALON SILVER,CRYSTAL HANDLE	X	X	X	1
46-1	3012331800	GASKET F DR AS	PVC-S	1			
47	3019072100	POCKET F	GPPS	2			
48	3010705401	BUSHING F DR CAP*U	POM	1			
49	30100C8U00	ASSY R DR	WHITE PCM,BASIC HANDLE_NON SPRAY , KEY TYPE	1	X	X	X
	30100C8U10		WHITE PCM,BASIC HANDLE_NON SPRAY , NON KEY TYPE	1	X	X	X
	30100C8U20		METALON SILVER,BASIC HANDLE_SPRAY , NON KEY TYPE	1	X	X	X
	30100C8U30		METALON SILVER,BASIC HANDLE_SPRAY , KEY TYPE	1	X	X	X
	30100C8UA0		WHITE PCM,CRYSTAL HANDLE , NON KEY TYPE	X	1	X	X
	30100C8UC0		METALON SILVER,CRYSTAL HANDLE , KEY TYPE	X	1	X	X
	30100C8UD0		METALON SILVER,CRYSTAL HANDLE , NON KEY TYPE	X	1	X	X
	30100C8S00		WHITE PCM,BASIC HANDLE_NON SPRAY , KEY TYPE	X	X	1	X
	30100C8S10		WHITE PCM,BASIC HANDLE_NON SPRAY , NON KEY TYPE	X	X	1	X
	30100C8S20		METALON SILVER,BASIC HANDLE_SPRAY , NON KEY TYPE	X	X	1	X
	30100C8S30		METALON SILVER,BASIC HANDLE_SPRAY , KEY TYPE	X	X	X	1
	30100C8SA0		WHITE PCM,CRYSTAL HANDLE , KEY TYPE	X	X	X	1
	30100C8SC0		METALON SILVER,CRYSTAL HANDLE , KEY TYPE	X	X	X	1
	30100C8SD0		METALON SILVER,CRYSTAL HANDLE , NON KEY TYPE	X			1
49-1	3012332000	GASKET R DR AS	PVC-S, FR-37.. Only	1			X
	3012331900		PVC-S, FR-39.. Only	X			1
50	3019071900	POCKET BOTL	GPPS	2			
51	3019072000	POCKET EGG	GPPS	1			
52	3019072200	POCKET JUMBO	GPPS	1			
53	3011198800	CASE EGG TRAY AS	CASE+VINYL	1			
54	3012555900	GUIDE POKT AS	DEO AS, NON SPRAY				
	3012555910		DEO AS, SPRAY, OPTION				
55	-	BASIC HANDLE (TYPE:1)					
55-1	3012662200	HANDLE F	BASIC HNDL	1	X	1	X
55-2	3011670600	DECO F HNDL	ABS				
	3011670610		DECO F HNDL PA	ABS+SPRAY , OPTION			
56	-	CRYSTAL HANDLE(TYPE:2)					
56-1	3012662300	HANDLE F	CRYSTAL HANDLE	X	1	X	1
56-2	301254100	FRAME F HNDL AS	FRAME+DECO AS				
57	-	BASIC HANDLE (TYPE:1)					
57-1	3012663300	HANDLE R AS	BASIC HNDL	1	X	1	X
57-2	3011670700	DECO R HNDL	ABS				
	3011670710		DECO R HNDL PA	ABS+SPRAY , OPTION			
58	-	CRYSTAL HANDLE(TYPE:2)					
58-1	3012663500	HANDLE R AS	CRYSTAL HANDLE	X	1	X	1
58-2	3012255100	FRAME R HNDL AS	FRAME+DECO AS				

- Some parts can be chaged for improving their performance without notice.

Date	Amendment Note