

NO	PART-CODE	PART NAME	SPEC.	Q'ty	
				Basic Model	Dispenser Model
1	-	ASSY CAB URT	-	1	1
2	3012933100	HINGE *T *R	PO T3.0+PAINT	1	1
3	3012933000	HINGE *T *L	PO T3.0+PAINT	1	1
4	3001434900	COVER HI *T *R	PP	1	1
5	3001434800	COVER HI *T *L	PP	1	1
6	3001434800	SWITCH H/BAR DR AS	SP101B-2DI	2	2
7	3014HR070	PCB MAIN AS	X22B	1	x
	30143HR080		22D3..(Non Inverter Comp.)	x	1
	30143HJ080		22D3..(Inverter Comp.)		1
	30143HR060		22F3..(Non Inverter Comp.)		
	30143HJ060		22F3..(Inverter Comp.)		
8	3011446001	COVER M/PCB BOX	PP(FB-72)	1	1
9	3013226800	HOSE ICE MAKER TUBE AS	220~240V/5W	x	1
	3013226810		110~127V/5W		
10	3012540200	GUIDE CAB W/TUBE A AS	X22.. MODEL	x	1
	3012519221		Y22.. MODEL	x	1
11	3011444100	COVER GUIDE CAB W/T A	PP	x	1
12	3001424100	COVER GUIDE CAB W/FILT	PP	x	1
13	3011203200	CLAMP W/TUBE C	HIPS	x	2
14	3012933500	HINGE *U *R AS		1	1
15	3010673800	BRACKET ADJ FOOT AS		1	1
16	3012933400	HINGE *U *L AS		1	1
17	3001433900	COVER CAB BRKT AS	PP	1	1

- Some parts can be chaged for improving their performance without notice.

No	Date	Note	Remark

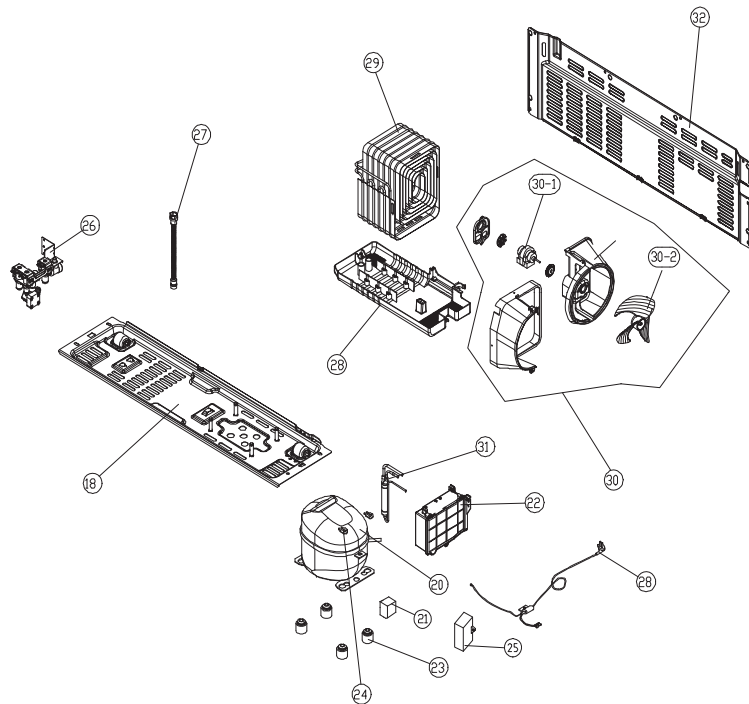

NO	PART-CODE	PART NAME	SPEC.	Q'ty	
				Basic Model	Dispenser Model
18	3010359600	BASE COMP AS	-	1	1
19	OPTION	CORD POWER AS	COUNTRY Dependent	1	1
20	3956183H4B	COMPRESSOR	MK183H-L2UB(220V/60HZ)	1	1
	3956183D2B		MK183D-L2UB(110~127V)		
	3956183Q5B		MK183Q-L2UB(220~240V/50Hz)		
	3956112250		DG125E11RAW5(220~240V/50Hz)		
	3956114M80		LQ140NAEM(220~240V/50Hz)		
	3959115280		EU4A5Q-L2X, Inverter Comp.	x	
21	3018129720	SWITCH P RELAY AS	265RFB, J531Q34E220M(MK183H-L2UB	1	1
	3018129710		445PHB, J531Q32E6R8M(MK183D-L2UB		
	3018129600		265RHB, J531Q35E330M(MK183Q-L2UB		
	3018129650		232NFB, PTH7M330MD2(DG12E11RAW		
	3018133900		4TM205RFB, 330M(LQ140NAEM)		
	3018133800		4TM319SFB(EU4A5Q), Inverter Comp.	x	
22	3814300300	BOX INVERTER AS	PP(EU4A5Q Only), Inverter Comp.	x	1
23	3010101600	ABSORBER COMP	NBR	4	4
	3010101480	ABSORBER COMP AS	NBR+SPRING		
24	3016002500	COMP WASHER	SK-5 T0.8	4	4
25	3016406100	CAPACITOR RUN	400VAC/5 μF (WIRE,P2)	1	1
	3016405900		350VAC/5 μF (WIRE, P2)		
	3016405020		250VAC/12 μF (WIRE,P2)		
26	3015406900	VALVE WATER AS	220~240V(Y22..MODEL)	x	1
	3015406910		110~127V(Y22..MODEL)		
	3015402300		220~240V(X22..MODEL)		
	301542310		110~127V(X22..MODEL)		
27	3013201700	HOSE DRN B	PE FRB-5970NB	x	1
28	3011199L00	CASE VAPORI AS	FRX-621B	1	1
29	3014467200	PIPE WICON AS	TWS OD4.76*0.7	1	1
30	3018410500	MOUTHBELL AS	FRX-621B	1	1
30-1	3015920900	MOTER C FAN	D4612AAA31	1	1
30-2	3011836300	FAN	PP OD3.17*D150	1	1
31	3019808100	DRYER AS	C1220T-M OD19.05*L135	1	1
32	3001436500	COVER MACH RM AS		1	1

- Some parts can be chaged for improving their performance without notice.

F-ROOM PARTS

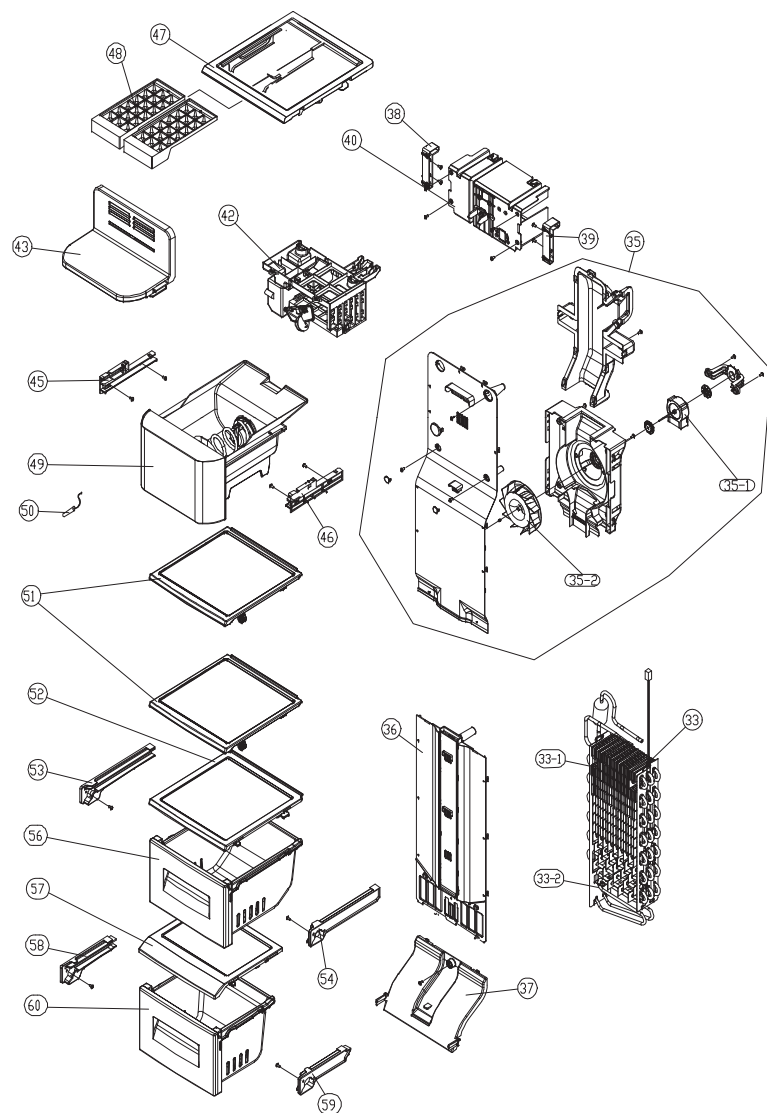

NO	PART-CODE	PART NAME	SPEC.	Q'ty	
				Basic Model	Dispenser Model
33	3017068900	EVA AS	220-240V, 280W	1	1
	3017068910		110-127V, 250W		
33-1	3014809500	SENSOR D AS	PBN-43	1	1
33-2	3012824210	HEATER SHEATH AS	220-240V, 280W	1	1
	3012824220		110-127V, 250W		
35	3018928600	LOUVER F A AS	FRY-621B	1	1
35-1	3015920700	MOTOR F FAN AS		1	1
35-2	3011836400	FAN F		1	1
36	3018928900	LOUVER F B AS	FRY-621B	1	1
37	3001434700	COVER F RETURN	HIPS	1	1
38	3012517800	GUIDE G MOTR BRKT*L	ABS		1
39	3012517900	GUIDE G MOTR BRKT*R	ABS		1
40	3010673600	BRACKET GEARED MOTR AS	FRX-601D, 220-240V	x	1
	3010673610		FRX-601D, 110-127V		
42	3012231400	FRAME I/MAKER AS	FRX-601D		1
43	3001435000	COVER I/CRUSHER*T	HIPS		1
45	3012538200	GUIDE I/CRUSHER *L	ABS		1
46	3012538100	GUIDE I/CRUSHER *R	ABS		1
47	3017851700	SHELF F ICE AS	FRX-621B	1	x
48	3011186300	CASE ICING	PP	2	x
49	3011199K00	CASE I/CRUSHER AS	FRX-601D	x	1
50	3014809300	SENSOR F AS	PT-38	1	1
51	3017851200	SHELF F AS		2	2
52	3001438000	COVER F CASE*T AS		1	1
53	3012514512	GUIDE CASE A *L AS	FR-S580EG(PP)	1	1
54	3012514612	GIDUE CASE A *R AS	FR-S580EG(PP)	1	1
56	3011124000	CASE F*T AS		1	1
57	3001434500	COVER F CASE *U	HIPS	1	1
58	3012529712	GUIDE CASE C *L AS	FRU-5711(PP)	1	1
59	3012529812	GUIDE CASE C *R AS	FRU-5711(PP)	1	1
60	3011124100	CASE F*U AS	FRX-621B	1	1

- Some parts can be chaged for improving their performace without notice.

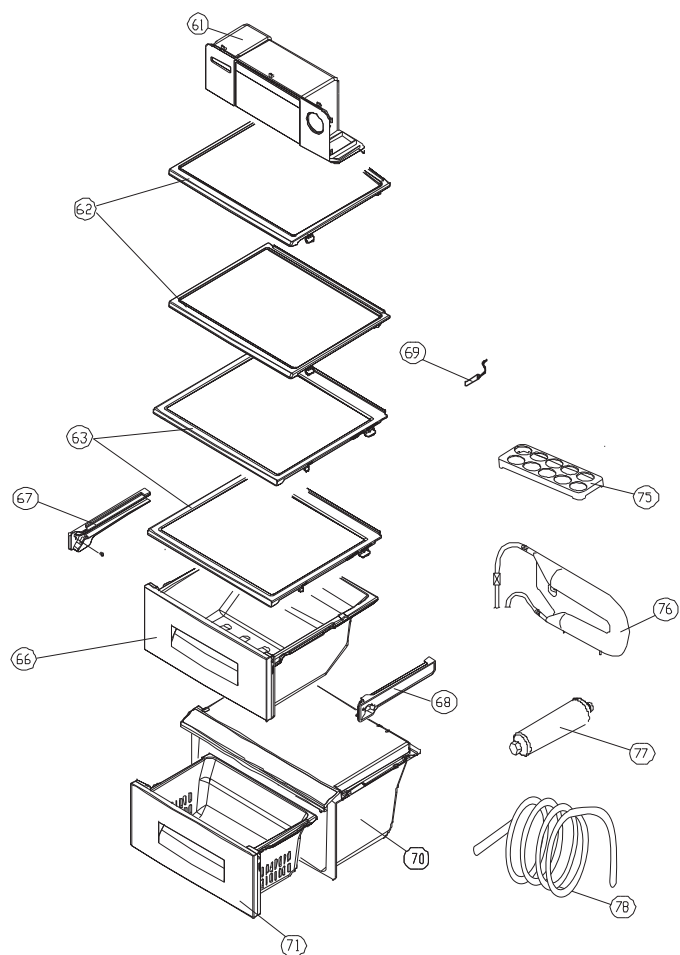

NO	PART-CODE	PART NAME	SPEC.	Q'ty	
				Basic Model	Dispenser Model
61	3001436900	COVER DAMPER AS	FRS-X22B, FRS-X22D..	1	1
	3001436910		FRS-Y22D..	x	
62	3017851300	SHEPLF R AS	FRX-621B	2	2
63	3001437200	COVER VEGETB CASE AS	FRX-621B	2	2
66	3011199P00	CASE VEGETB* M AS	FRX-621B	1	1
67	3012514512	GUIDE CASE A *L AS	FR-S580EG(PP)	1	1
68	3012514612	GIDUE CASE A *R AS	FR-S580EG(PP)	1	1
69	3014809400	SENSOR R AS	PBN-43B	1	1
70	3001438100	COVER CHANGE RM AS	FRX-601G	1	1
71	3011124200	CASE VEGETB *U AS	FRX-621B	x	x
75	3011190800	CASE EGG TRAY	GPPS(CRYSTAL)	1	1
76	3018201000	TANK WATER AS	FRU-541D	x	1
77	3019974800	S/PART FILT WATER AS	X22.. MODEL	x	1
	3019986700		Y22.. MODEL	x	
78	3019974020	S/PART W/TUBE AS	X22.. MODEL	x	1
	3019974070		Y22.. MODEL	x	

- Some parts can be chaged for improving their performance without notice.

No	Date	Note	Remark

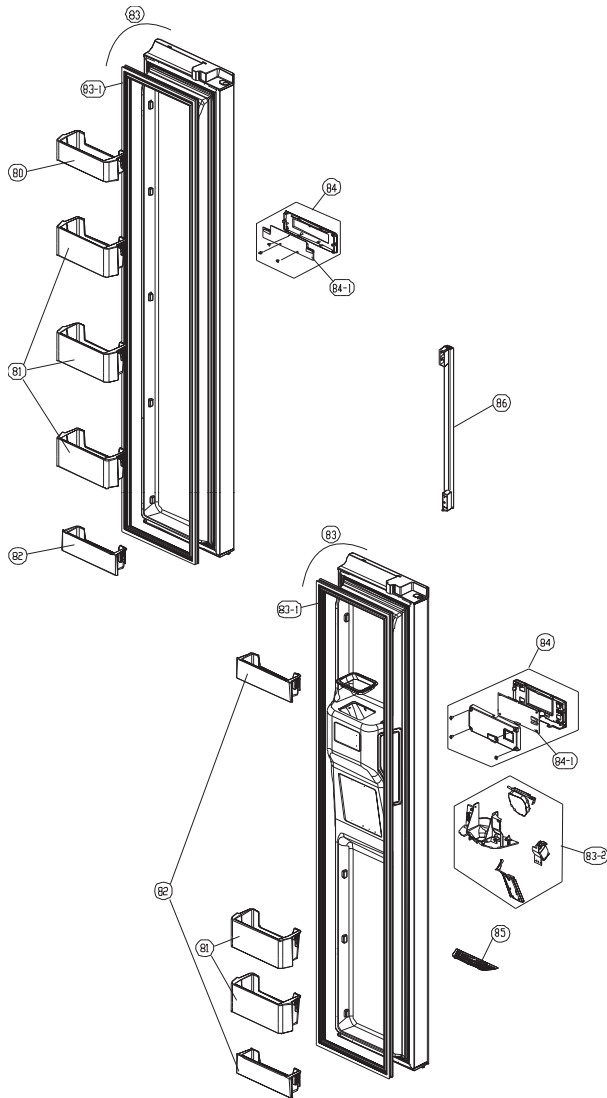

NO	PART-CODE	PART NAME	SPEC.	Q'ty	
				Basic Model	Dispenser Model
80	3019058000	POCKET F*T	GPPS	x	2
81	3019057900	POCKET F*M	GPPS	1	x
82	3019058100	POCKET F*U	GPPS	3	2
83	30100A4H70	ASSY F DR	FRX-623, DWH1C	1	X
	30100A4H60		FRX-623, TSH5E		
	30100B7210		FRX-603, DWH1C	x	1
	30100B7200		FRX-603, TSH5E		
83-1	3012318860	GASKET F DR AS	FRX-621B	1	1
83-2	3010574300	BOX DISPNS I/SHUT AS	220-240V/50Hz	x	1
	3010574310		110-127V/60Hz		
84	3014250900	COVER F PCB AS	FRX-623	1	x
	3014250700	PANEL *F CONTL AS	FRX-603	x	1
84-1	30143JP160	PCB FRONT AS	FRX-623	1	x
	30143JM160		FRX-603	x	1
85	3012407800	GRILLE DISPS	ABS	x	1
86	3012657810	HANDLE F DR AS	FRX-603F, SPRAY	1	1

- Some parts can be chaged for improving their performace without notice.

No	Date	Note	Remark

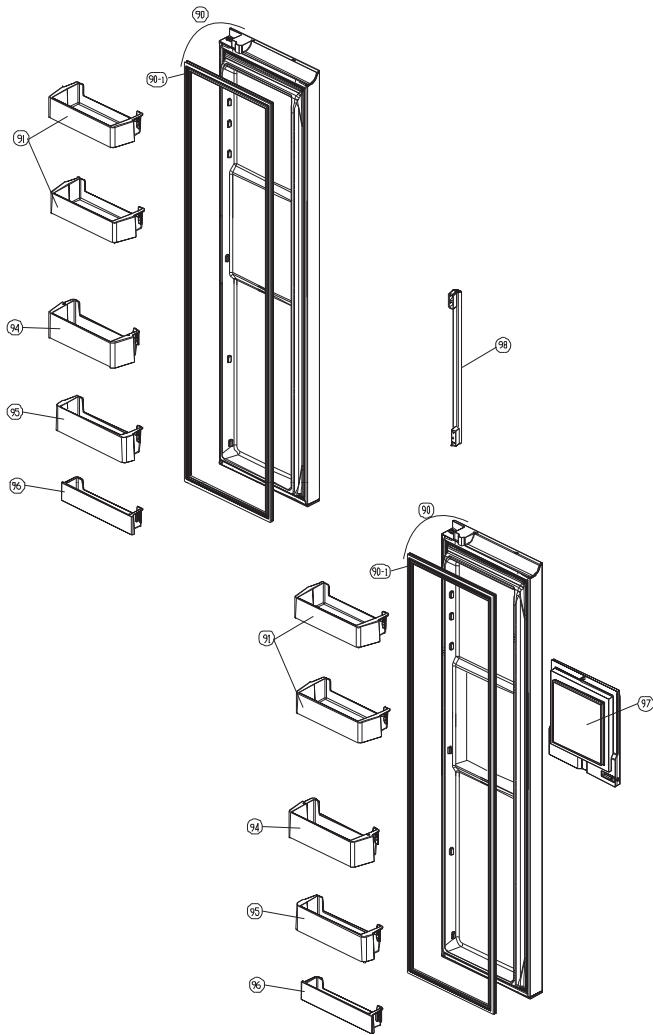

NO	PART-CODE	PART NAME	SPEC.	Q'ty	
				Non H/Bar Door	H/Bar Door
90	30100B7710	ASSY R DR	FRX-603D, DWH1C	1	x
	30100B7700		FRX-603D, TSH5E		
	N/D		FRX-603F, DWH1C	x	1
	N/D		FRX-603F, TSH5E		
90-1	3012318960	GASKET R DR AS	PVC+MAGNET	1	1
91	3019058420	POCKET R*T	GPPS	2	2
94	3019058600	POCKET R H/BAR	GPPS	1	1
95	3019058300	POCKET R*M	GPPS	1	1
96	3010058500	POCKET R*U	GPPS	1	1
97	3001707720	DOOR H/BAR AS	TITANIUM	1	1
	3001707730		WHITE		
98	3012657910	HANDLE F DR AS	FRX-603F, SPRAY	1	1

- Some parts can be chaged for improving their performance without notice.

No	Date	Note	Remark