



# Service manual

Model: RN-H320S

## Contents

- 1 Cover
- 2 The cooling system
- 3 The electrical diagram
- 4 Trouble shooting guide
- 5 Exploded view
- 6 Spare part list

# The cooling system

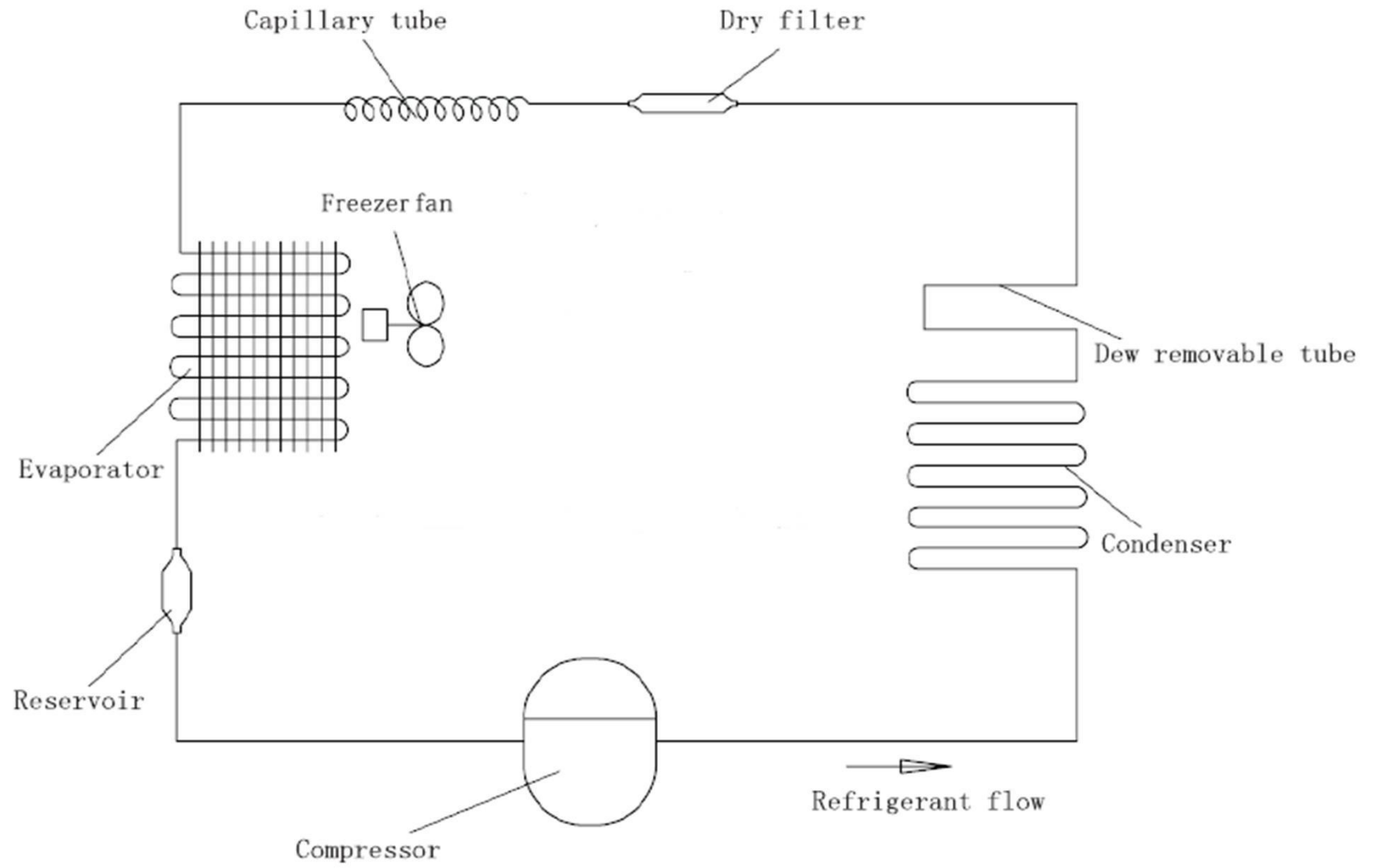

αD T 1/6 Δ↑↑(U) ↓○LE↑LI

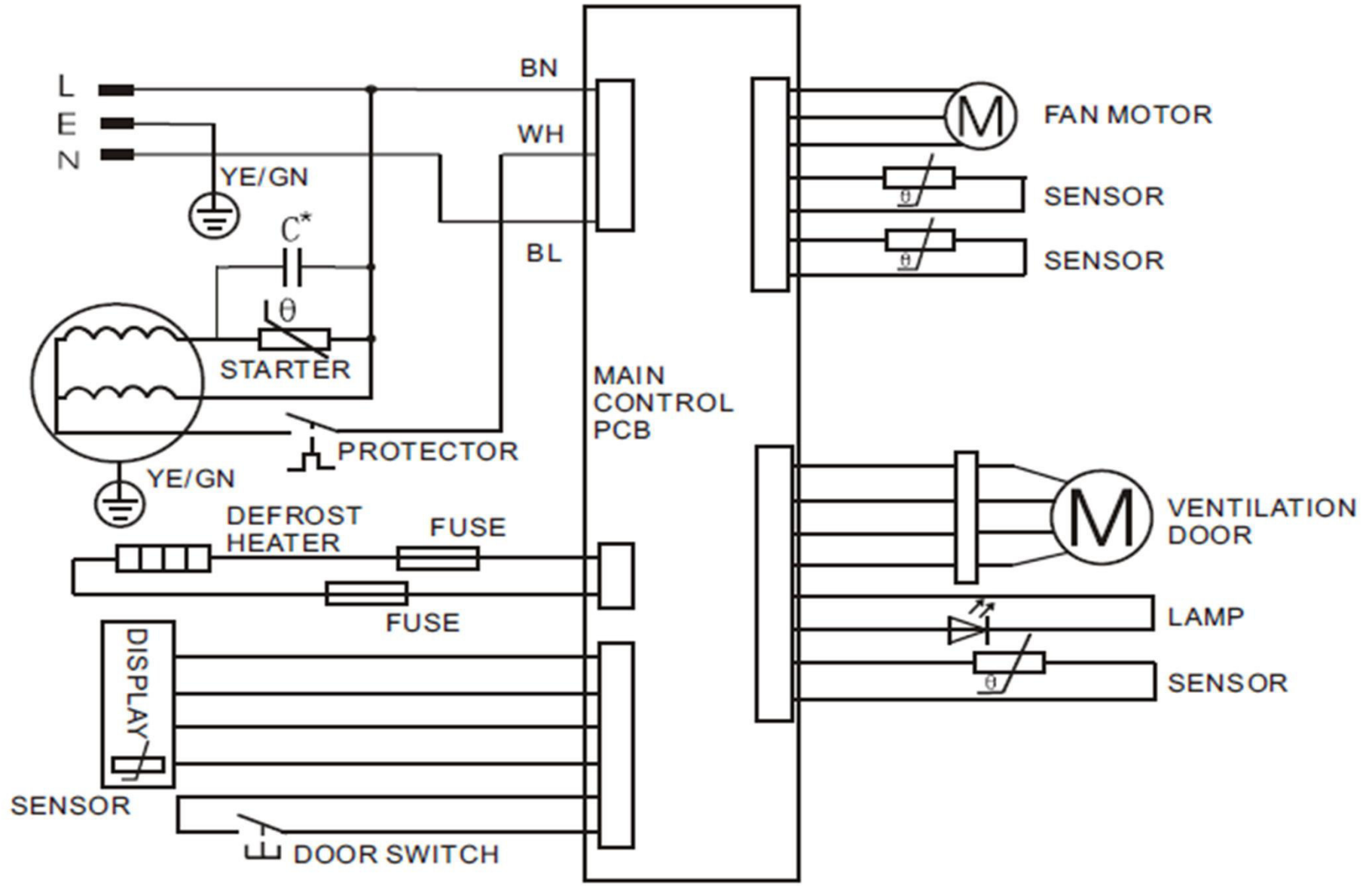

## Trouble shooting guide

No	Problem	Possible Cause	What To Do
1	Fan no work	the the fan motor is failure and replace it with a new one	open the cover board of air duct in freezer room, check the fan if it no running, then measure the voltage between the red wire and black wire of fan, if the voltage is 12V, the the fan motor is failure and replace it with a new one
2	No defrost. Freezer room temperature no enough cold and refrigerator room OK and open the cover board of are duct and find ice formation on evaporator	the drainpipe contain impurity	disconnect power, and let the ice defrost and inspect the water if it is flow through the drainpipe, if could not flow out, check if it contain impurity and clean the drainpipe
		the sensor failure or PCB failure	check the fuse if it is melt or not. If the fuse is melt, it mean that the sensor failure or PCB failure, need change the sensor or PCB.
		the defrost heater is break or PCB failure	inspecting the CN4 defrost heater two connector. If the heater is OK then it must be PCB failure and change the PCB.
3	the temperature of freezer and refrigerator are no enough cold and the temperature no change by adjusting the potentiometer (thermostat)	the potentiometer failure	inspect the potentiometer (thermostat), and measure the resistance value by adjusting the potentiometer (thermostat), if the resistance value no change by adjusting the potentiometer (thermostat),
		the sensor failure	When the sensor failure and the compressor will be running like this´ if the potentiometer (thermostat) setting below 3 position, the compressor will be running 20 minutes and then stop 30 minutes, if the potentiometer (thermostat) setting more than 3 position, the compressor will be running 30 minutes and then stop 20 minutes. If find the compressor work like above situation, it mean the sensor failure and need open the back of refrigerator and change sensor of refrigerator evaporator

		no problem	the time between two starting is shorter than 12min; or refrigerator room temperature is lower than the setting temperature, in this case, it is no problem. You need waiting more time.
4	Compressor no starting	PCB failure	PCB had automatic self-examination: open the cover of PCB at the back of product, plug in power and push the SW101 switch 3 seconds and the PCB begin automatic self-examination program, then the led and compressor and fan and defrost heater all work two second and then stop, all wore one time and then quit automatic self-examination program, and the program will return the original setting. If the automatic self-examination program no work, it mean the PCB failure and need change it
		Compressor wire not right or compressor damage	measure the voltage of compressor input connector, if it is OK then check the starting and relay of compressor, also check the wire if it is OK
6	product no any work	the PCB failure	check the power by multimeter, if the input voltage is 220V -240, but the led, compressor, fan, defrost heater are all no work, it mean the PCB failure and need change a new PCB

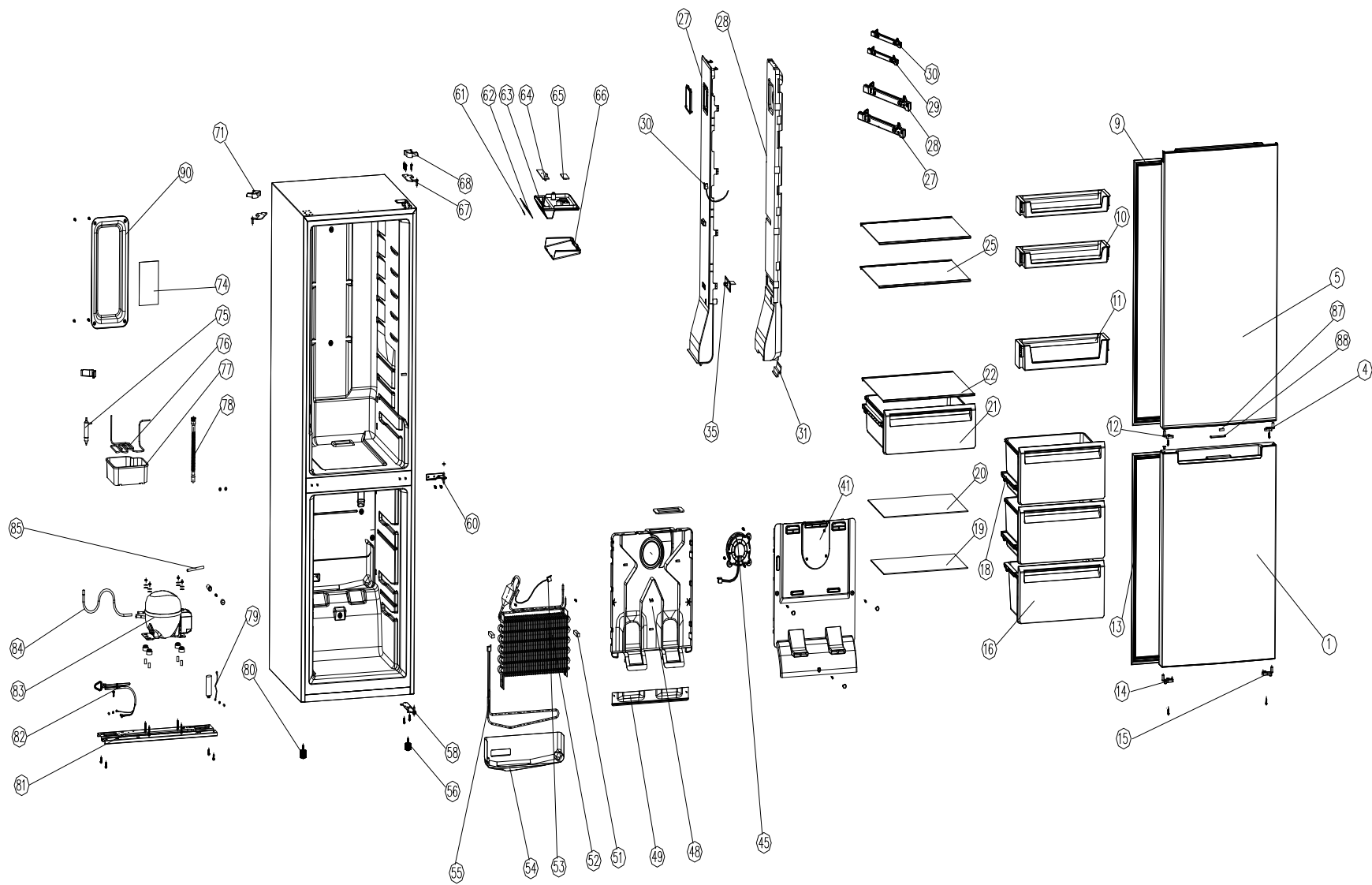

## RN-H320S Parts list

No.	Parts code	Description of Spare Part	Quantity
1			1
4	2208510008	Right limit block of door	1
5			1
9	2200200016	Upper door gasket	1
10	20122050716	Upper door Middle balcony	2
11	20122050717	Upper door lower balcony	1
12	2208510009	Left limit block of door	1
13	2200200017	Lower door gasket	1
14	2208510011	Lower door left aid-closer	1
15	2208510010	Lower door right aid-closer	1
16	2207300051	Lower Drawer	1
18	2207300050	Upper Drawer	2
19	3071300098	Freeze Glass partition,Lower	1
20	3071300097	Freeze Glass partition,Upper	1
21	2106140018	Crisper drawer	1
22	2106120155	Cover of Crisper Box	1
25	2106100023	S helf of refrigerator chamber	2
27	2208500066	Front C over of refrigerator wind parts	1
28	2701000131	Foam of refrigerator wind parts	1
30	2501100008	Temperature sensor	1
31			1
35	2208100310	Manual damper lever	1
41	20122990684	Decorative block of Freeze wind parts	1
45	3059900040	DC centrifugal motor assembly	1
48	20122990683	Freeze wind parts bracket	1
49	3039900346	Water board of freeze wind parts	1
51			2
52	3040300072	Fin Evaperator	1
53	3059900038	Temperature sensor	1
54			1
55	3050700022	drip tray of calorifie	1
56	20122990782	S hort adjust leg	1
58	3031400198	Lower door hinge assembly	1
60	3031400029	Middle Door Hinge	1
61	2207100148	thermostat button	1

62	2209100178	Display control panel	1
63			1
64	2500300043	Display circuit board	1
65	3050400025	LED light	1
66	2208100247	Cover of ceiling light	1
67	3031400197	Upper door hinge assembly	1
68	2208100246	Upper door hinge Cover	1
71	20122080161	Upper door hinge Cover,Left	1
74	2500300042	Control board assembly	1
75	3040500011	Drier filter	1
76	20114010106	Evaporative condenser	1
77	20122990705	Drain pan	1
78			1
79			1
80	20122990781	Long adjust leg	1
81			1
82	3050100093	Power supply cord plug	1
83	2400100074	Compressor	1
84			1
85			1
86			1
87	2501100002	Door switch,Magnetic control	1
88	20122990674	Door switch cover,Magnetic control	1
90	2208100428	Cover of Control board	1